

Model	Service Bulletin Description	Number
All	Water softeners O-rings Tygon tubing Back flow prevention Contactors SSM water filter parts Serial Number Format Change Ice machine sanitation after a boil order Color and Model Series Change	PS-6-88 PS-9-88 PS-2-89 PS-9-92 PS-1-98 PS-8-98 PS-8-2004 PS-7-2005 PS-6-2006
AC125	Water inlet valve New leg parts	PS-1-89 PS-7-97
AF300	New oil seal New water shed New motor and motor housing	PS-12-2002 PS-15-2003 PS-1-2005
AFE325	New oil seal New water shed New motor and motor housing New compressor	PS-12-2002 PS-15-2003 PS-1-2005 PS-5-2005
AFE400	Drain and water system parts Bin thermostat bracket change TXV change New oil seal New water shed New motor and motor housing New compressor Added hi pressure cut out	PS-11-97 PS-4-2000 PS-13-01 PS-12-2002 PS-15-2003 PS-1-2005 PS-5-2005 PS-1-2006
Bins	Door frames Gasket color change BH260 and BH375 parts BH360 bin SB480 bin BH1100, BH1300, BH1600 bin Ice Express Service Parts Ice Express Cart Service Parts BH801 Service Parts BH1100, 1300, 1600 changes	PS-2-2000 PS-4-2000 PS-14-2000 PS-8-2002 PS-4-2003 PS-6-2003 PS-2-2004 PS-3-2004 PS-10-2004 PS-5-2006
CD200	Built in thermostat Cube cutter removal Agitation timer New push button switch	PS-9-97 PS-11-97 PS-4-98 PS-2-99

Model	Service Bulletin Description	Number
CME256	Solenoid strainer PTCR change Top panel Bin thermostat kit Panel change Service ice sensor WC condenser Air intrusion kit New controller Controller revision	PS-6-99 PS-7-2000 PS-8-2000 PS-11-2000 PS-5-2002 PS-6-2002 PS-11-2002 PS-7-2003 PS-10-2003 PS-3-2005
CME306	Transformer Control System Service ice sensor New controller C series – TXV change Controller revision	PS-4-2001 PS-4-2002; PS-6-2002 PS-10-2003 PS-7-2004 PS-3-2005
CME456	Transformer Control system Service ice sensor WC condenser New controller C series – TXV change Controller revision	PS-4-2001 PS-4-2002 PS-6-2002 PS-11-2002 PS-10-2003 PS-7-2004 PS-3-2005
CME506	Hot gas valve coils Solenoid valve strainer PTCR change Top panel Bin thermostat kit Panel & TXV change Service ice sensor WC condenser Air intrusion kit New controller Controller revision	PS-6-98 PS-6-99 PS-7-2000 PS-8-2000 PS-11-2000 PS-5-2002 PS-6-2002 PS-11-2002 PS-7-2003 PS-10-2003 PS-3-2005

Model	Service Bulletin Description	Number
CME656	Hot gas valve coils New front panel Solenoid strainer PTCR change Top panel Bin thermostat kit Transformer Panel change Service ice sensor WC condenser Air intrusion kit New controller Controller revision	PS-6-98 PS-1-99 PS-6-99 PS-7-2000 PS-8-2000 PS-11-2000 PS-4-2001 PS-5-2002 PS-6-2002 PS-11-2002 PS-7-2003 PS-10-2003 PS-3-2005
CME806	PTCR Change Top panel Bin thermostat kit Transformer Panel change Service ice sensor WC condenser Air intrusion kit New controller Controller revision	PS-7-2000 PS-8-2000 PS-11-2000 PS-4-2001 PS-5-2002 PS-6-2002 PS-11-2002 PS-7-2003 PS-10-2003 PS-3-2005
CME855	Harvest time change New superheat Hot gas valve coils	PS-5-96 PS-10-96 PS-6-98
CME865R	Refrigerant charge Harvest time change New superheat Hot gas valve coils High pressure cut out change	PS-4-96 PS-5-96 PS-10-96 PS-6-98 PS-9-98
CME1002R	Refrigerant charge Harvest time change New superheat Hot gas valve coils High pressure cut out change	PS-4-96 PS-5-96 PS-10-96 PS-6-98 PS-9-98

Model	Service Bulletin Description	Number
CME1056	Top panel change PTCR Transformer Panel change Service ice sensor WC condenser Controller revision	PS-8-2000 PS-12-2000 PS-4-2001 PS-5-2002 PS-6-2002 PS-11-2002 PS-3-2005
CME1202 or CME1402	Refrigerant charge Harvest time change New superheat New control circuit Hot gas valve coils	PS-4-96 PS-5-96 PS-10-96 PS-5-97 PS-6-99
CME1356 and CME1656	Controller cover Solenoid strainer Controller mounting C series top panel change PTCR Transformer Stacking Panel and controller change Ice sensors Service ice sensors WC condenser Air intrusion kit Controller Cover Controller revision	PS-3-99 PS-6-99 PS-8-99 PS-6-2000 PS-13-2000 PS-4-2001 PS-7-2001 PS-3-2002 PS-4-2002 PS-6-2002 PS-11-2002 PS-7-2003 PS-4-2004 PS-3-2005
CME1856	Compressor mounting grommets Controller cover Controller revision	PS-14-2003 PS-4-2004 PS-3-2005
CME2006	Controller cover Solenoid strainer Controller mounting C Series top panel change Transformer Panel insulation kit Stacking Service ice sensor Compressor mounting grommets Controller cover Controller revision	PS-3-99 PS-6-99 PS-8-99 PS-6-2000 PS-4-2001 PS-5-2001 PS-7-2001 PS-6-2002 PS-14-2003 PS-4-2004 PS-3-2005
CMS Cubers	Sonar change	PS-1-93

Model	Service Bulletin Description	Number
CMS1202	Harvest time Panel changes	PS-2-92 PS-4-92
CMS1402	Harvest time Panel changes	PS-2-92 PS-4-92
CS55	Water inlet valve New leg parts Spray nozzles	PS-1-89 PS-7-97 PS-12-01
CSE60	Fan motor and blade	PS-5-2003
CSW1	Grid change	PS-7-95
CSWE1	Compressor change	PS-8-97
CSW45	Drain pump hose Update Compressor change C series D series	PS-9-2000 PS-9-2001 PS-11-2001 PS-3-2003 PS-8-2003
DMS	Mounting change	PS-2-95
ERC	Part numbers Refrigerant charge ERC301 fan motor No vertical installations Common service parts Revised common service parts	PS-2-96 PS-4-96 PS-3-98 PS-3-2000 PS-3-2001 PS-5-2004
Flakers	Coupling noise Water system parts Remote accumulators New control board New oil seal RO water limitation New oil seal New water shed Non vented gear reducer	PS-5-93 PS-11-97 PS-7-99 PS-5-2000 PS-10-2000 PS-1-2001 PS-12-2002 PS-15-2003 PS-2-2006
FM800, FM1200, FM1500, FM2400	Phasing Input seal change Drip pan change New control board Chute insulation New Drive Motor	PS-13-90 PS-4-2000 PS-5-2000 PS-10-2000 PS-16-2000 PS-12-2003

Model	Service Bulletin Description	Number
FME800, FME1200, FME1500, FME2400	Bearing lubrication Water system parts Remote accumulators Input seal change Drip pan change New control board Chute insulation New Drive motor Fan bracket change	PS-14-96 PS-11-97 PS-7-99 PS-4-2000 PS-5-2000 PS-10-2000 PS-16-2000 PS-12-2003 PS-6-2005
FME804, FME1204, FME1504, FME2404	WC condenser change Wiring diagram New drive motor Fan motor bracket Panel and air flow change	PS-11-2002 PS-9-2003 PS-12-2003 PS-6-2005 PS-3-2006
HD356	C series panel change Transformer Drain pan, coin op and cam changes	PS-2-2000 PS-4-2001 PS-9-2002
HD30N	Coin mechanism timer change	PS-4-2006
IS100, 120, 150, 220	Sweep arms Ice retainer No adapter	PS-11-97 PS-6-2001 PS-8-2001
Kits	Service part numbers	PS-18-92
MAR	Parts update Pulley and key update	PS-1-2003 PS-4-2005
MDT2	Wiring diagram New sink drain New dispensing control panel Panel change	PS-11-2003 PS-13-2003 PS-9-2004 PS-9-2005
MDT3,4	Changes Carton, chute and bin bottom New oil seal Water shed New Service Auger Sensor label cover removal New motor and motor housing Portion control kit	PS-10-2001 PS-10-2002 PS-12-2002 PS-15-2003 PS-1-2004 PS-6-2004 PS-1-2005 PS-2-2005
MDT5, MDT6	WC condenser change Sensor label cover removal Portion control kit	PS-11-2002 PS-6-2004 PS-2-2005
MFE400	New Service Auger New motor and motor housing	PS-1-2004 PS-1-2005

Model	Service Bulletin Description	Number
ND550, ND650	Vane and motor change Input seal change New control board	PS-6-97 PS-4-2000 PS-10-2000
NDE550, NDE650	Vane and motor change Drain fitting Input seal change New control board	PS-6-97 PS-11-97 PS-4-2000 PS-10-2000
ND750	Input seal change New control board	PS-4-2000 PS-10-2000
NM650, NM950, NM1250, NM1850	Input seal change New control board Chute insulation Drive motor parts	PS-4-2000 PS-10-2000 PS-16-2000 PS-12-2003
NME650, NME950, NME1250, NME1850	Bearing lubrication Water system parts Input seal change New control board Chute insulation Drive motor parts	PS-14-96 PS-11-97 PS-4-2000 PS-10-2000 PS-16-2000 PS-12-2003
NME654, NME954, NME1254, NME1854	WC condenser change Wiring diagram Drive motor parts Fan motor bracket Ice and beverage dispenser applications Panel and air flow change	PS-11-2002 PS-9-2003 PS-12-2003 PS-6-2005 PS-8-2005 PS-3-2006
Remote Systems	Soak out change	PS-4-95
RS100, 120, 150, 220	Sweep arms No adapter	PS-11-97 PS-8-2001

Model	Service Bulletin Description	Number
SCE170	Drain fitting Hot gas valve coil Rotated control Auto HPC New compressor TXV change WC condenser	PS-11-97 PS-6-98 PS-7-98 PS-10-98 PS-15-2000 PS-13-01 PS-11-2002
SCE275	PTCR Transformer Control System WC condenser change Controller location change Controller revision	PS-2-2001 PS-4-2001 PS-7-2002 PS-11-2002 PS-2-2003 PS-3-2005
SLC/SLE Cubers	Top panel	PS-11-97
TDE	Drain fitting Sensor covers Sensor label removal	PS-11-97 PS-4-2000 PS-6-2004

SERVICE BULLETIN

SUBJECT: Water Softeners Used with Scotsman Ice Makers

In many areas, softening the water supply produces a water that is superior for washing clothes, bathing and other day to day activities. "Hard Water" really means water that minimizes soap suds, requiring more soap to be used.

However, when "soft" water is used to produce ice in a commercial ice machine, the soft water is usually NOT an improvement over "hard" water.

This is due to the similarity between "hard" and "soft" water.

Hard water is water that contains excessive dissolved minerals, usually calcium and magnesium. Soft water is hard water that has been treated to remove the calcium and/or magnesium and replace it with sodium. This means that if there were high concentrations of calcium or magnesium in the water, after it has been softened there will be a high concentration of sodium.

Any mineral dissolved in water will lower the freezing point of that water. An example is adding salt to snow on the roads in winter. The salt lowers the freezing point so the snow melts at temperatures below 32°F.

Another way of saying that is: *water that is more pure freezes first.* An example is the refrigerator freezer ice cube tray. When tap water is poured in, and the tray placed in the refrigerator freezer, ice forms from the outside in (the outside giving up heat to the surrounding cold air). After all the water has frozen, the ice in the center will be more cloudy than the ice on the edges, because the pure water froze at a higher temperature and sooner.

When ice is forming on the evaporator of a commercial ice cube machine the temperature of the ice on the water side remains near 32°F. because of the 32°F. water flowing over it. The evaporator temperature may fall as low as 0°F., and the ice nearest the evaporator will be colder than 32°F., but the outside of the ice - where additional freezing is taking place - is very near 32°F. At that temperature, only the purest water will freeze. Any impurities will cause the water's freezing point to be below 32°F. and that water will not freeze.

That is one of the main reasons why ice produced from a commercial ice cube machine has fewer minerals and is clearer than home refrigerator ice. In some areas, the supply water has such a high concentration of minerals that even commercial cube ice will be produced with a temperature below 32°F. Ice like that appears snowy and tends to fuse quickly.

The water that is left in the sump at the end of the freeze cycle contains a concentrated solution of minerals, irregardless of whether it began as hard or soft water. How the sump water is rinsed from the ice machine varies: there may be an overflow, a siphon or a pump out.

Softened water is not a complete answer for all water conditions. If there are also suspended solids in the water, having soft water will be an incomplete answer, because water softeners do not take out suspended solids. Furthermore, if a water softener were to fail and inject brine (salt water) into the water supply of the ice machine, the results would be catastrophic to the metal components of the ice machine.

In view of the above, Scotsman does not recommend water softeners as a singular type of water treatment for ice machines.

SERVICE BULLETIN

SUBJECT: NEW COMPRESSOR AND MODEL NUMBER CHANGE

The CM450, CM650, and CM650R will now be manufactured as an **E** model:

- CM450AE-32**E**, CM450AE-3**E**, CM450WE-32**E**, CM450WE-3**E**
- CM650AE-32**E**, CM650AE-3**E**, CM650WE-32**E**, CM650WE-3**E**
- CM650RE-32**E**, CM4650RE-3**E**

The basic change involved is a new compressor, and related electricals.

Single phase (-32) models use compressor **18-8000-02**, potential relay 18-1903-46, start capacitor 18-1901-48, and run capacitor 18-1902-45.

Three phase (-3) models use compressor **18-8000-03**.

Three new service manuals are now available for these new models:

CM450 = 17-1865-01

CM650 = 17-1866-01

CM650R = 17-1868-01

The prior service manuals will remain effective for the A through D models of these products.

The new compressors are NOT directly interchangeable with the A through D compressors, and the old compressors will remain available as service parts.



Scotsman[®]

PS-9-88

September, 1988

Revised May 2007

SERVICE BULLETIN

SUBJECT: O-RINGS

Listed below are the size specifications of the O-Rings that Scotsman sells.

Part Number	ID	OD	CS
13-0617-01	1/2	11/16	3/32
13-0617-02	3/4	15/16	3/32
13-0617-03	1-1/2	1-3/4	1/8
13-0617-04	5/16	7/16	1/16
13-0617-05	7/8	1-1/16	3/32
13-0617-06	2	2-3/8	3/16
13-0617-07	1-7/8	2-1/16	3/32
13-0617-08	1/4	7/16	3/32
13-0617-09	1	1-1/8	1/16
13-0617-10	3/8	9/16	3/32
13-0617-11	15/16	1-3/16	1/8
13-0617-13	9/16	3/4	3/32
13-0617-14	1/8	1/4	1/16
13-0617-15	1-5/8	1-7/8	1/8
13-0617-16	1	1-1/4	1/8
13-0617-17	7-1/4	7-1/2	1/8
13-0617-18	4-1/2	4-3/4	1/8
13-0617-20	2-1/2	2-3/4	1/8
13-0617-22	7/8	1-1/8	1/8
13-0617-23	5/8	3/4	1/16
13-0617-24	13/16	1-1/16	1/8
13-0617-25	11/16	7/8	3/32
13-0617-26	7/16	5/8	3/32
13-0617-28	3/16	5/16	1/16
13-0617-29	1-1/16	1-1/4	3/32

Part Number	ID	OD	CS
13-0617-30	5/8	13/16	3/32
13-0617-31	1-3/8	1-5/8	1/8
13-0617-32	1/4	3/8	1/16
13-0617-33	1-3/16	1-7/16	1/8
13-0617-34	6-3/4	7	1/8
13-0617-35	1/4	1/2	1/8
13-0617-36	27/64	43/64	1/8
13-0617-37	1-3/4	1-7/8	1/16
13-0617-38	8-1/2	8-11/16	3/32
13-0617-39	1-1/16	1-1/4	3/32
13-0617-40	2-3/4	3	1/8
13-0617-41	1-1/16	1-7/16	3/16
13-0617-42	3/8	1/2	1/16
13-0617-43	1-1/4	1-5/8	3/16
13-0617-44	3-1/2	3-3/4	1/8
13-0617-45	3-1/4	3-1/2	1/8
13-0617-46	3-1/2	3-13/16	5/32
13-0617-48	3/4	7/8	1/16
13-0617-49	3-1/4	3-3/8	5/64
13-0617-50	2-1/8	2-3/8	1/8
13-0617-52		3-7/16	3/32
13-0617-53	1-3/4	2-3/16	
13-0617-54	2-13/16	3	3/32
13-0617-56	1 1/8	1 3/8	9/64
13-0617-57	7/16	9/16	5/64

SERVICE BULLETIN

SUBJECT: AC55, CS55 and AC125 INLET WATER SOLENOID VALVES

SYMPTOM: Water flows into the machine too fast during the harvest cycle.

CAUSE: Flow restrictor behind the inlet screen of the valve is missing, loose, or in backwards.

FIX: Check the flow restrictor by:

1. Remove the inlet screen by using a pliers to pull it out.

2. If the flow restrictor is in properly, the brass portion of it will be **secure** in the plastic valve body, and the black rubber portion will have about 1/4" diameter visible in the center.

If the flow restrictor is not there, there will be no brass visible.

If the flow restrictor is in backwards, there will only be a 1/16" diameter hole visible in the center of the brass insert.

Flow Rates: AC55 and CS55, Part Number A32405-001 - .21 g.p.m.

AC125: Part Number A32405-002 - .48 g.p. m.

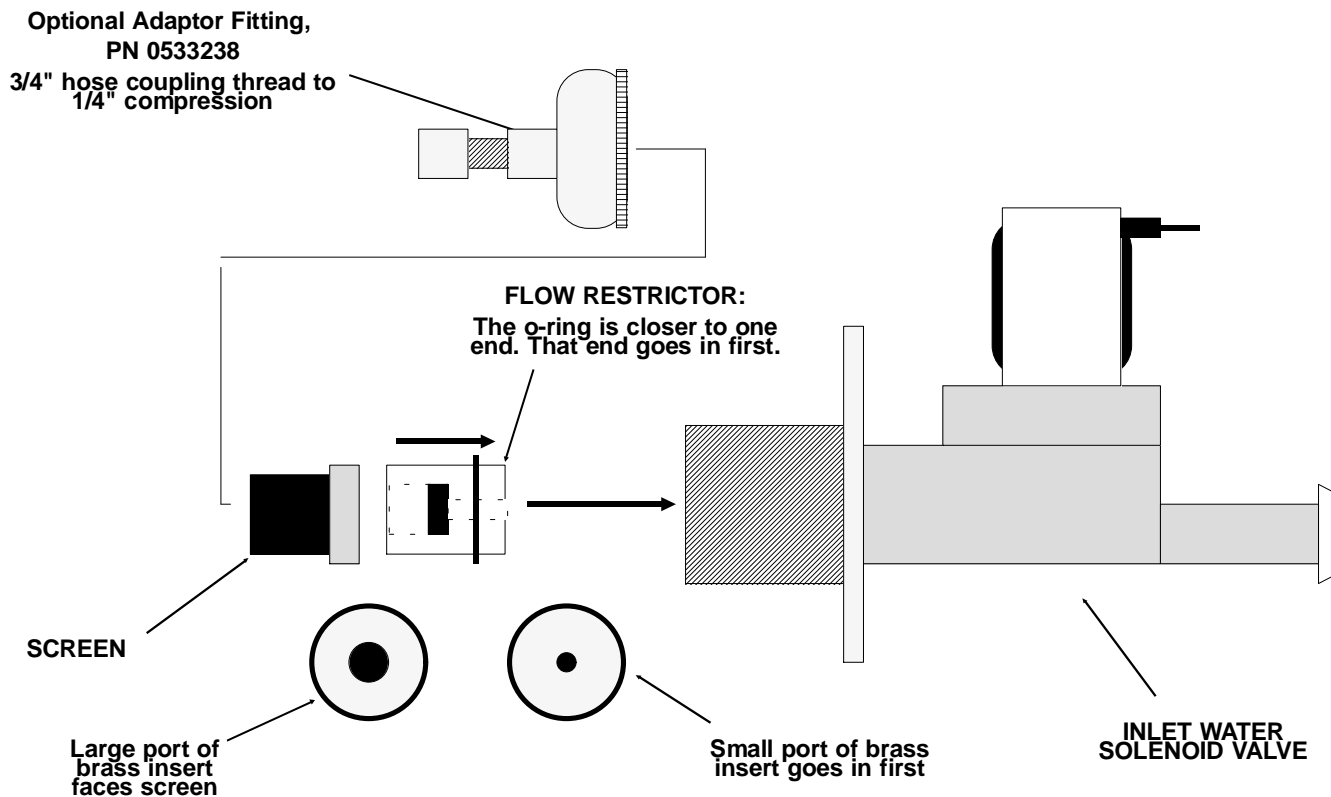



PS-2-89

June, 1989

SERVICE BULLETIN

SUBJECT: "VINYL" OR "TYGON" TUBING

Scotsman sells several sizes of vinyl tubing. This clear, flexible tubing is suitable for potable water (NSF and FDA listed). This tubing is used in many areas of ice machine construction, but not where there is high water pressure.

The table below lists the part numbers and sizes of this tubing. All fractions are in inches.

All of this tubing is sold by the foot: to order 20 feet of a particular size of tubing for stock, order a quantity of 20 of that part number.

Part Number	Inside Diameter	Outside Diameter	Wall Thickness
13-0674-01	1/4	7/16	3/32
13-0674-02	3/8	9/16	3/32
13-0674-03	7/16	5/8	3/32
13-0674-04	1/2	11/16	3/32
13-0674-06	5/8	13/16	3/32
13-0674-07	3/4	1	1/8
13-0674-08	7/8	1 1/8	1/8
13-0674-09	1/2	3/4	1/8
13-0674-10	9/16	13/16	1/8
13-0674-13	5/8	7/8	1/8
13-0674-15	1/2	5/8	1/16
13-0674-16	5/8	3/4	1/16



PS-13-90

October 1990

SERVICE BULLETIN

SUBJECT: FM2400R FAN RELAY PHASING

The FM2400R (or NM1850R) has a fan relay in it to control the output of line power to the remote condenser fan motor.

This relay must be properly "phased", or it will burn out its contacts.

The wiring diagram for the machines is correct, but the wires may not be in their proper places, especially if there has been a premature failure. When replacing the relay, the wires must be placed on the proper terminals, or there will be another failure.

To check:

1. In the fan relay box, check the wiring from the terminal strip to the relay, see the illustration for terminal identification. (Placement of 9 & 7 is not critical).
2. Make sure that the power is on.
3. Make sure both compressors are operating.
4. Use a voltmeter to check the power at the terminal strip in the fan relay box. It must be as illustrated below.

If the voltage is not as shown, reverse the wires from the right unit only.

TO RELAY TERMINALS:

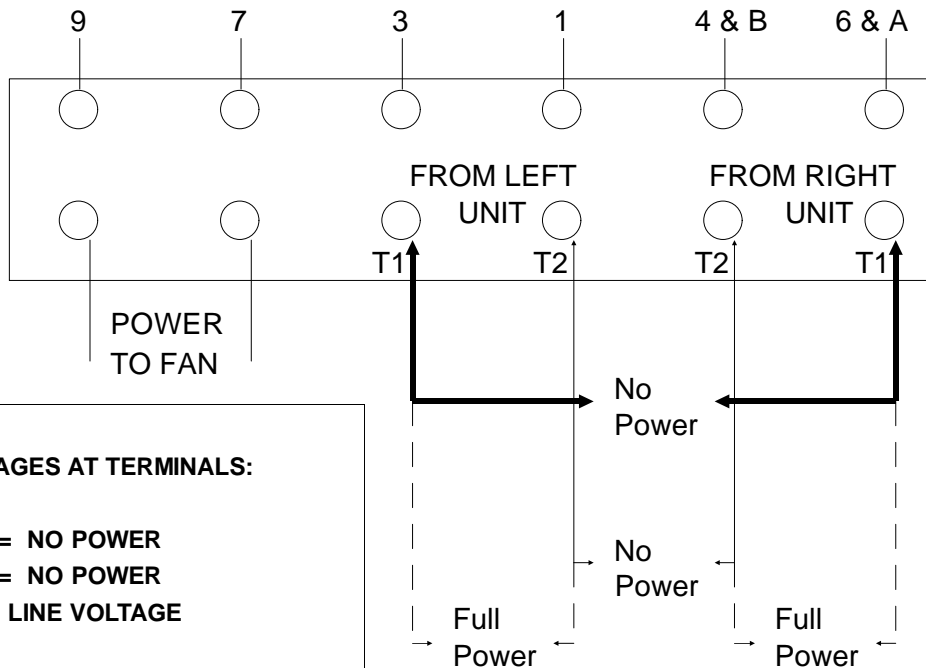

CORRECT VOLTAGES AT TERMINALS:

T1 to T1 = NO POWER
 T2 to T2 = NO POWER
 T1 to T2 = LINE VOLTAGE

Note: T1 and T2 illustrate which compressor contactor terminals in the main control boxes the wires come from.

The wires from the contactors are supposed to be connected to the terminals as shown.

There are NO terminal identifications at the terminal strip.



PS-1-91
January 1991

SERVICE BULLETIN

SUBJECT: FM/ND/NM/NS Models, breaker, chute clamp and breaker cover change.

Beginning with January 1991 production, a clamp was added to the above models to help secure the ice chute assembly to the breaker. This required a change to the breaker; a groove was machined into the bottom of the breaker, and it is that groove that the clamp hooks into. This clamp is not retrofitable to prior ice machines. Service breakers at this time do not have the groove. The part number of the breaker and cover did not change.

The breaker cover has been changed from a stainless steel part that required a tool to remove, to a plastic part that can be removed by hand. Threads are still left-hand.

CHANGES TO CHUTE - EXPLODED VIEW

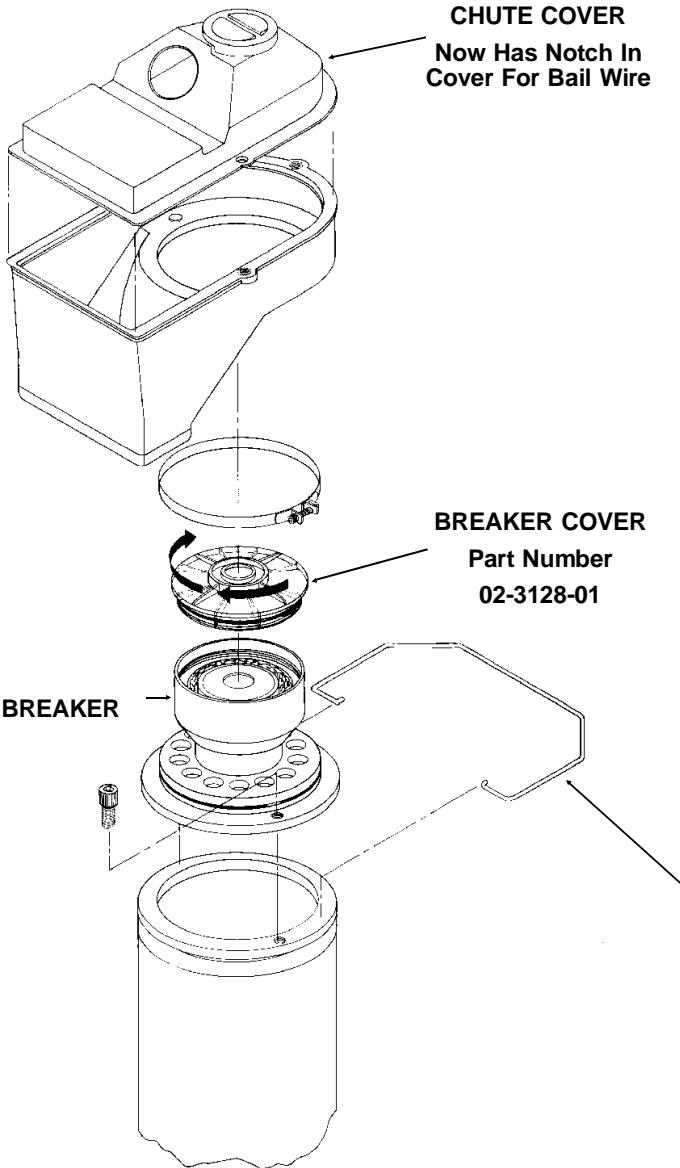

CHANGES TO CHUTE - ASSEMBLED

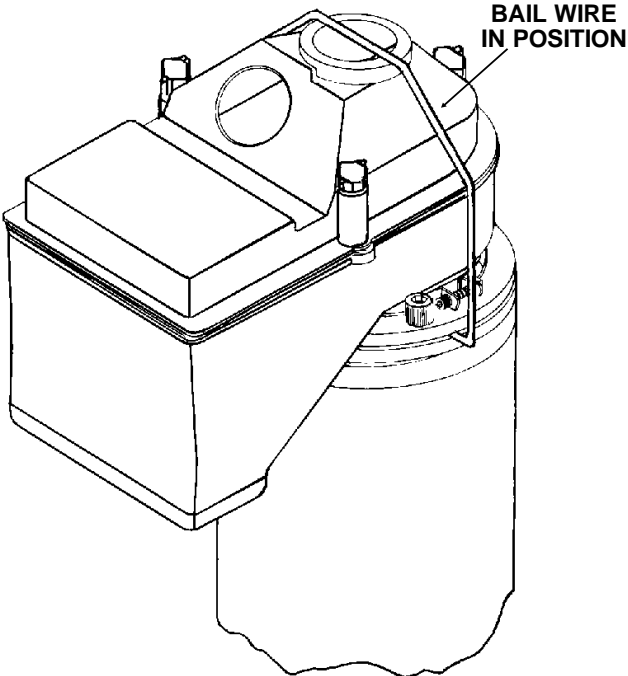



PS-14-91
October 1991

SERVICE BULLETIN

SUBJECT: Ranco Thermostat Altitude Adjustment

Scotsman currently specifies the Ranco brand of thermostat for use in its ice machines. Some of the thermostats are not adjustable, but do have an adjustment for altitude.

This table describes that adjustment. The altitude refers to the location of the ice machine. The amount of adjustment is in degrees of rotation of the adjustment screw.

Thermostat Part Number	Adjustment	Altitude (ft. above sea level)	Amount of adjustment (from factory setting)
11-0354- (all)	Range Screw CW	2,000	35°
		4,000	90°
		6,000	145°
		8,000	190°
11-0353- (all)		2,000	55°
		4,000	160°
		6,000	250°
		8,000	340°

Do NOT adjust these thermostats for any reason other than high altitudes.

Note: To adjust, rotate screw number of degrees from factory position.



SERVICE BULLETIN

SUBJECT: Cuber Harvest Time

Scotsman cubers are shipped from the factory with the timer set at an *average* harvest time. Upon initial start up, the harvest time may need to be changed. Harvest time adjustments are detailed in the service manual shipped with each cube ice machine, but in all cases should be set for no less than 15 seconds after the last cube has fallen into the bin.

Cubers require more time to defrost or harvest the ice cubes in the winter than they do in the summer, and cubers that are started in the summer may need to have the harvest time lengthened in the winter. Although changes should be coordinated with the time of the semi-annual cleaning, it is impractical to readjust the harvest time whenever the air and water temperatures change. The harvest time may be set with upcoming temperature changes in mind.

Harvest time is dependant upon the temperatures of the air and water to the ice machine; for example:

Model	Condenser Air Temp	Room Air Temp	Water Temp	Suggested Harvest Time
CMS1402R	0°F.	50°F.	40°F.	3.5 - 4 minutes
	0°F.	70°F.	55°F.	3 - 3.5 minutes
	90°F.	90°F.	70°F.	2.25 minutes
CMS1402A	n/a	50°F.	40°F.	3.5 minutes
	n/a	70°F.	50°F.	2.5 - 3 minutes
	n/a	90°F.	70°F.	2 - 2.25 minutes

Most cubers are shipped with the harvest time set at 2 ¼ minutes. The exceptions to this are models set at 3.5 minutes:

- CM500R
- CM1400R
- CM1000W & R
- CM855W & R
- CMS1402A, W & R*
- MCM860W & R
- MCM1462A, W & R

* Was 2 ¼ minutes. Remote changed in late February 1992, air and water cooled changed mid March 1992.



PS-4-92

April, 1992

SERVICE BULLETIN

SUBJECT: CMS1202B and CMS1402B Series

A "B" series of these two ice machines is now in production. The major change is to the front panel. The B series will have **two** front panels with captured fasteners and plastic bumpers on the bottom edge of the panels. The new front panels are much easier to use: the captured fasteners will stay with the panels; the plastic bumpers help align the panels; and having two panels eliminates the need to expose the complete front of the ice machine for cleaning or service.

The new series machines require new stacking and panel kits:

CMS/MCM KITS

	CMS1002	MCM860	MCM1062	CMS1202A or CMS1402A	CMS1202B or CMS1402B	MCM1462
STACKING	KSCMS	KSMCM	KSMCM	KSCMS	KSCMS48*	KSMCM48**
TRIM	-	-	-	KTCMS48	-	-
PANEL	SPKCMS1002	-	-	SPKCMS1402	SPKCMS48	-

* Includes gaskets & trim strip.

** Includes gaskets, trim strip and legs. Trim strip for "B" series stacking kit holds upper edge of front panels in place.

KITS FOR STACKING ON A PRIOR MODEL (not new, information only)

CMS1002 ONTO CM1000	CMS1202 ONTO CM1400	CMS1402 ONTO CM1400
KSCMSX2 or KSCMSX2B	KSCMSX1 or KSCMSX1B	KSCMSX1 or KSCMSX1B

Stacking kits with a "B" suffix have a rubber transducer housing. B series units will stack onto prior models the same as A series units.

New part numbers:

Left front panels: A35400-002 - stainless steel and A35400-001 - painted.

Left front panel screws: 03-1678-02

Right front panels: A35401-022 - stainless steel and A35401-021 - painted. Includes liner & insulation.

Right front panel screws: 03-1678-04

Plastic support bumpers: 02-3252-01

Capture rings for fasteners: 03-1678-03

Speed clip for front panel fasteners: 03-1678-01

SCOTSMAN®

PS-9-92

June, 1992

SERVICE BULLETIN

SUBJECT: Back Flow Prevention

Scotsman ice machines are N.S.F. listed. One of the requirements of a N.S.F. listed ice machine is back flow prevention of the potable water system. Internal to all Scotsman Ice Machines is an air-gap between the inlet water valve and the water level in the reservoir; this is the back flow prevention design.

If back flow prevention is required on the water cooled condenser circuit, it will have to be added.

SERVICE BULLETIN

SUBJECT: CD200 Changes

There have been some recent changes to the CD200.

1. There is a new lock and key for the sink assembly:

- The part number for a lock and key is 02-3262-20.

Use of this new lock and key began with serial number 573742-04Y. The lock and key may be used to replace the prior assembly.

Replacement key kits include keys for the prior lock and the current lock.

- The part number for the key kit is: 02-3263-20.

2. The dam screens used in the drain pan of the CD200 have been changed to a one piece design. The new part number is A35542-001. The change began with sn 562864-03Y.

3. The gasket used on the top of the CD200 has been changed to the standard bin top edge gasket, pn 19-0503-04 (requires 9 ft, order this gasket by the foot).

4. The nut securing the dispense rotor to the drive shaft has been changed, and the new number is 02-3221-01.

5. The ice chute hood pn 02-1994-20 includes the instruction label.

6. The new card kit (KCARD) uses a microswitch, the part number is 12-2450-01.



PS-18-92
November, 1992

SERVICE BULLETIN

SUBJECT: New "Kit" Service Parts

Kit	Description	Part Number
KSEALER	Holder, tape roll	02-3261-01
BGS10	Ice chute	02-3259-01
KADNM1	Access cover	A35004-001
	Ice chute	A35005-001
	Ice shield	02-3142-01
	Bearing	02-3125-01
KFMI	Wire (4 connections)	12-2424-01
	Wire (2 connections)	12-2423-01
KCM25	Lock and key	02-3114-20
	Relay	02-3114-21
	Cash box	02-3114-22
	Switch	02-3114-23

SERVICE BULLETIN

SUBJECT: Sonar Ice Level Control Change

A change has been made to the sonar ice level control, beginning with with CMS and MCM machines manufactured after April, 1993 (date code -10L and higher).

The Sonar Board has had a function light added to indicate the status of the signal to the transducer and up to the relay on the sonar board. If this light is ON:

- There is power to the machine
- The transformer is OK
- The transducer is OK
- The board is OK up to the relay
- The ice level is below the selected setting, and the machine should be making ice.

The transducer has also been changed. An additional circuit has been added, connecting low voltage power to an internal resistor (a small heater). The new sonar board has a connection for the new transducer. An adapter cord is required to use the new transducer with the older boards, and is included with the transducer kit described below.

Two kits have been developed:

- A sonar board kit that will adapt to **any** MCM or CMS model. The kit part number is: **12-2376-21**
- A transducer kit that will adapt to **any** MCM or CMS model. The kit part number is: **A34908-021**

All orders for older transducers or boards will be cross-referenced to the kits.

A service diagnosis table is included at the back of the bulletin.

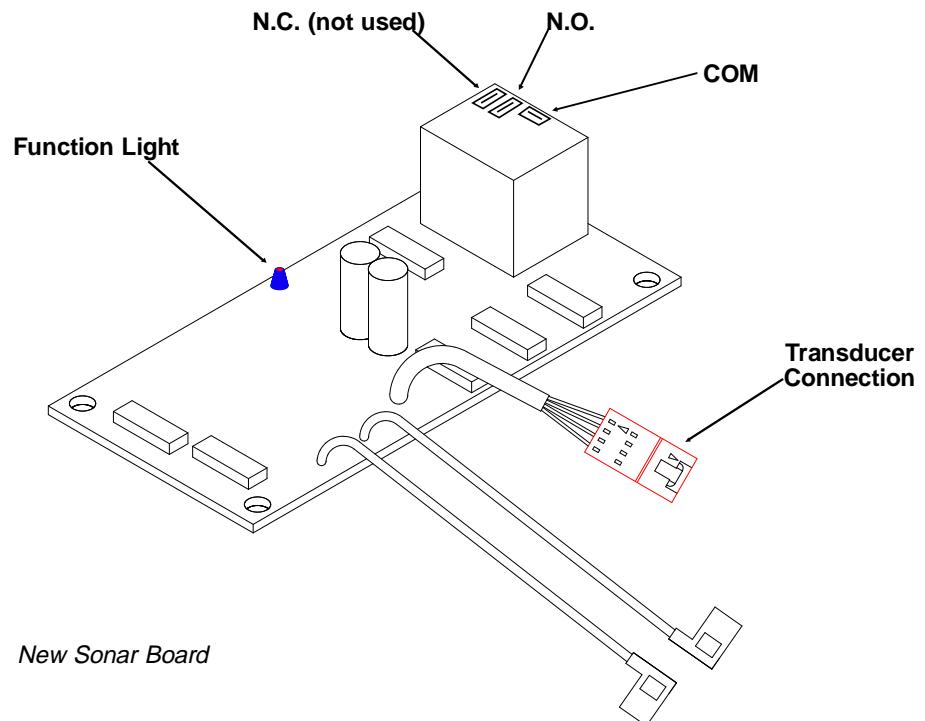

New Sonar Board

SERVICE BULLETIN

SUBJECT: Small Flaker Coupling Noise

The correct diagnosis of any service problem is critical to making a correct repair. When small flakers (those using the 1/10 H.P. gearmotor - models such as AF1, AF325, FD470, and MF400) produce a "clicking" or "snapping" sound, one of the most likely possible problems is mis-alignment between the auger shaft and the gearmotor output shaft. The sound is produced by the motion of the coupling between the two shafts because of the mis-alignment. The noise may **seem** to come from the evaporator. Another clue is finding aluminum "dust" from the coupling on the gearcase cover.

A quick test is to spray some lubricant on the auger shaft at the top of the coupling. If the noise stops, mis-alignment is the problem. The proper repair is to replace the following parts:

1. The coupling, part number A29915-002. Be sure to grease it when re-assembling.
2. The adapter, part number 08-0595-01.
3. Gaskets, part numbers 13-0628-00 and 02-1505-00.
3. The gearmotor cover, part number A28165-021. Check the oil and gears when the gearmotor is apart.
4. Also check the splines of the auger, they may have become damaged and then the auger must be replaced also.

Scotsman is now shipping replacement gearmotors with the adapter included to insure that this critical part is changed.

SCOTSMAN[®]

Bulletin Number: PS-2-95

Bulletin Date: January 1995

SERVICE BULLETIN

Subject: DMS Machine Stand Change

The NDE550, NDE650, TDE550 and TDE650 have threaded holes in their bases at the corners. These threads are used to fasten the dispenser to the DMS21B machine stand. Bolts and washers are now being packed with the machine stands for this purpose.

Note: The bolt size is $\frac{5}{16}$ - 18, 1".

SERVICE BULLETIN

Subject: R-404A Remote System Installation and Initial Start Up

Effective immediately, the requirement for a 12 hour pre-heating of the compressor before initial start up (also known as a "soak out") has been changed.

The new requirement is for a 4 hour "soak out". This change applies to all Scotsman **Commercial R-404A** (HP62) remote condenser systems. It does NOT apply to Rapid Freeze industrial machines.

This bulletin supersedes any information previously supplied by Scotsman, including what is printed in the service manuals packaged with the R-404A commercial remote condenser machines.

A "soak out" begins when electrical power is connected to the remote condenser ice machine (and the compressor is off). When power is supplied, the crankcase heater begins to warm the base of the compressor to evaporate any refrigerant that may be in the oil from run test. Without this external source of heat, liquid refrigerant may still be mixed with the oil when the compressor starts. If refrigerant is mixed with oil, when the compressor starts the sudden lowering of the internal compressor pressure, coupled with crankshaft agitation, causes the refrigerant to evaporate and the oil to foam. Because foam does not properly lubricate a compressor, starting a compressor with liquid refrigerant in the oil causes internal wear and possible valve damage. **A "soak out" is a simple process that prolongs compressor life.**

For this reason, most ice machine compressor manufacturers recommend a "soak out", some for as long as 12 hours. Copeland, Scotsman's supplier, recommends a 4 hour soak out. Scotsman believes that this supplier recommendation is important enough to make it a requirement for all of its applicable commercial products.

To maximize efficiency, Scotsman suggests that one of the first steps when installing a remote system (after placing the machine on the bin) is to connect the electrical power to the ice machine. After that proceed with the balance of the installation. By the time the installation has been completed, the 4 hour soak out time should have passed.

After 4 hours of electrical connection, the king valve may be opened and the compressor started.

SERVICE BULLETIN

Subject: New Remote Condenser Series

The ERC series of remote condensers replaces the RCE type. The parts are not interchangeable. Use this bulletin for parts information. See sales literature for product applications.

ERC Series Remote Condenser

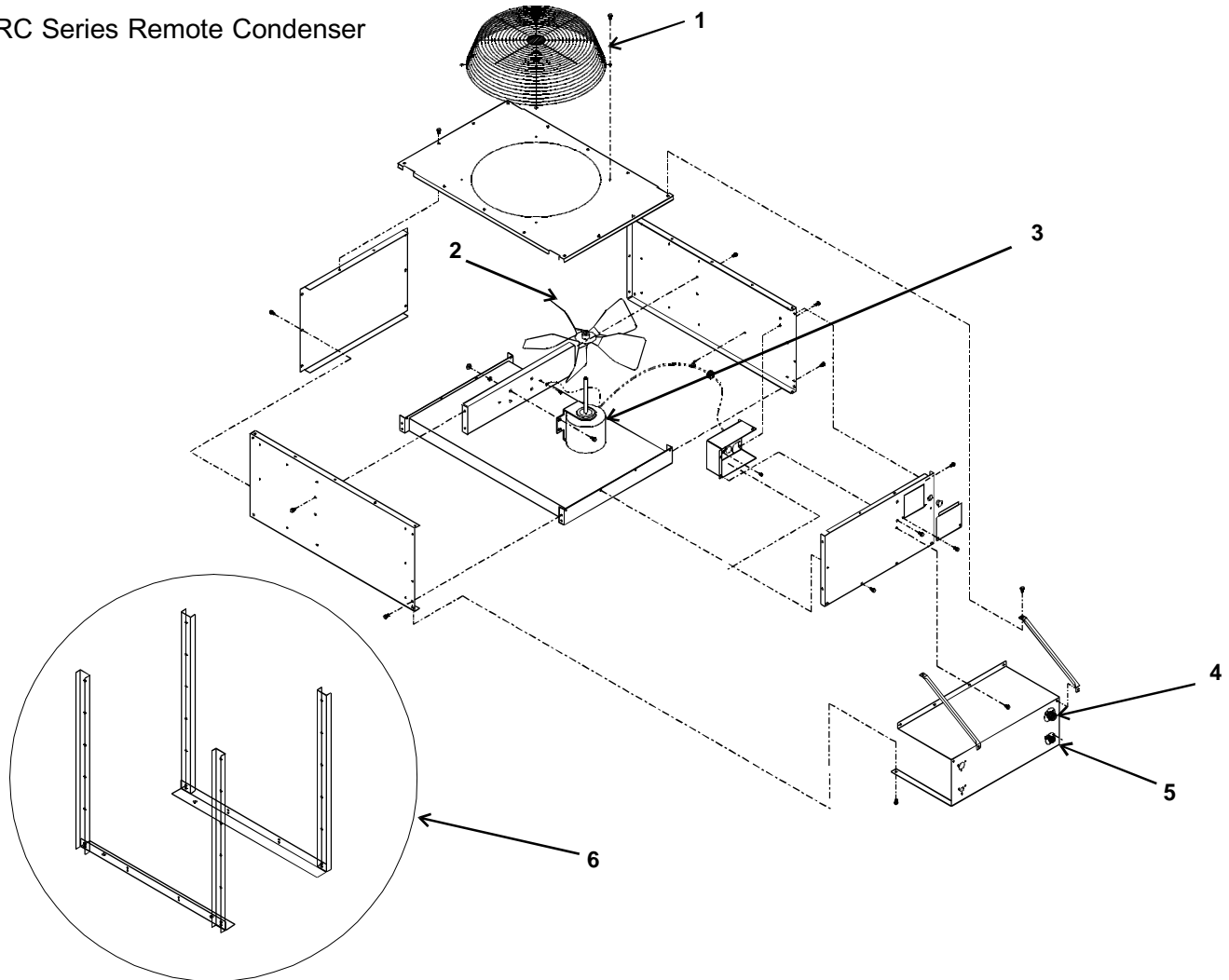

ITEM NUMBER	PART NUMBER	DESCRIPTION
1	02-3575-01	Fan guard
2	18-8800-01	Fan blade
3	18-8796-01	Fan motor ERC101
	18-8796-32	Fan motor ERC151, ERC201, ERC301, ERC302, ERC401, ERC402
4	16-0850-01	Quick connect, discharge
5	16-0850-03	Quick connect, liquid
6	A36990-001	Leg kit for ERC101, 151, 201, 301, 302
	A36990-002	Leg kit for ERC401, 402





Bulletin Number: PS-4-96

Bulletin Date: June 1996

SERVICE BULLETIN

**Subject: Cuber & Remote Condenser Refrigerant Charge Quantity Changes.
All use R-404A. This bulletin supercedes other published charge information.**

Ice machine model:	Charge contained in the ice machine was:	Charge contained in the ice machine is now:	Remote Condenser Model	Charge contained in ERC condensers is now:	Total System Charge (or recharge amount)
CME506R	208 oz	224 oz	ERC101	3 oz holding charge	224 oz*
CME656R	208 oz	232 oz	ERC201	3 oz holding charge	232 oz*
CME656R	208 oz	232 oz	ERC402	48 oz/circuit	280 oz
CME865R	288 oz	288 oz	ERC301	48 oz	336 oz*
CME1002R**	288 oz	288 oz	ERC301	48 oz	336 oz*
CME1202R**	336 oz	336 oz	ERC401	112 oz	448 oz*
CME1402R**	336 oz	336 oz	ERC401	112 oz	448 oz*

Bold indicates change.

Units manufactured beginning with date code 11A (May 1996) contain these charges. Exact cuber serial number starting points are on the back of this bulletin.

1. Recharge system based on total system charge requirements.

- Identification of the ice machine and the condenser it's connected to is required to determine the correct charge.

2. Use new charge weights for refrigerant warranty reimbursement. Model number of the condenser must be on the claim.

3. When recharging prior installations, use the table above.

- When a prior condenser (RCE1401) is connected to a CME1202R or CME1402R, that system should be charged as if the condenser was an ERC401.
- When a prior condenser (RCE1001) is connected to a CME865R or CME1002R, that system should be charged as if the condenser was an ERC301.

4. Mark the new charge on machines that have been recharged.

* Nameplate Charge Numbers - note that CME656R uses 232 oz charge unless it is connected to an ERC402.

** If connected to a McDonald's MAC 7G use standard ice machine charge.

Note: Length of line set does not change Total System Charge.

SERVICE BULLETIN

Cuber Refrigerant Charge Change Starting Serial Numbers

CME506RE thru CME656R	925009-11A
CME1002RS-3	929795-11A
CME1002RE-3	929826-11A
CME1002RE-32	929824-11A
CME1002RS-32	929828-11A
CME865RE-32	929820-11A
CME865RS-32	929832-11A
CME865RE-6	929831-11A
CME865RS-6	929833-11A
CME1002RE-6	929827-11A
CME1002RS-6	929829-11A

Nameplate charge change starting serial numbers:

same as above plus:

CME1202RE-3	925005-10A
CME1202RS-3	925006-10A
CME1202RE-32	925004-10A
CME1202RS-32	924989-10A
CME1402RE-3	925007-10A
CME1402RS-3	925008-10A
CME1402RE-32	924993-10A
CME1402RS-32	924998-10A

SERVICE BULLETIN

Subject: Timer Change

Models Affected: CME1202 and CME1402; CME865 and CME1002; CME855 and CME1000

CME1202 and CME1402

Beginning with serial number 945616-01A:

60 Hz Timer part number changed to: **12-2628-22**

50 Hz Timer part number changed to: **12-2628-26**

This timer has a 10 minute total cam revolution, the original had a 8 minute total cam revolution. This allows a maximum harvest time of 4:48 instead of the prior 4:00 minute maximum harvest. Preset harvest time remains at 3:30 minutes. This change was made because on some units a harvest cycle longer than 4 minutes is required to consistently release all ice. This timer may be applied to those prior machines that need extra harvest time.

CME865 and CME1002

and

CME855 and CME1000

Beginning with serial number 945715-01A:

60 Hz Timer part number changed to: **12-2107-22**

50 Hz Timer part number changed to: **12-2107-26**

The timer is still the 8 minute type. Preset harvest time changed to 3:30 minutes, it was 2:40.

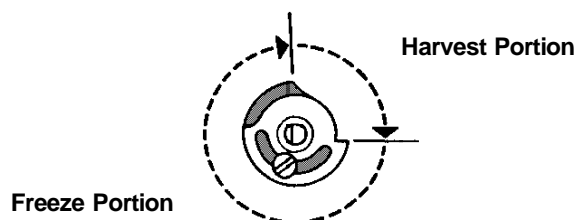
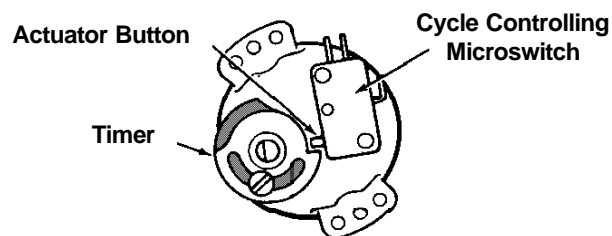



Bulletin Number: PS-10-96

Bulletin Date: August 1996

SERVICE BULLETIN

Subject: TXV Superheat Change

The TXVs used on the CME855, CME865, CME1000, CME1002 and CME1202 and CME1402 have had a change to the superheat setting. The change began with the following models and serial numbers:

CME1202AE-32	948567-01A
CME1202AE-3	950786-01A
CME1202RE-32	946713-01A
CME1402AE-32	948588-01A
CME1402AE-3	950789-01A
CME1402RE	950690-01A
CME1402AS	950794-01A
CME1402RS	950796-01A

All other CME1202s or CME1402s with the new setting will have a date code of -02A or higher. CME855-CME1002 will have this change beginning with date code -03A.

The new setting is: 8-10°F.

This includes part numbers:

- 16-0878-21 (CME855-1002)
- 16-0882-21 (CME1202-1402)

Replacement 16-0882-21 TXVs shipped after 7/30/96 have the new superheat setting.

SERVICE BULLETIN

Subject: CD200 and CME256, CME506, CME656 (CM³)

Two new kits are now available for use on the above package:

1. Baffle & Timer kit, part number **A37077-001**. This kit consists of a stainless steel baffle that mounts to the top of the CD200, just below the ice drop area of the CM³ machine. This baffle directs the harvesting ice towards the back of the hopper. The kit also contains a **2 hour** off-cycle agitation timer. Other kit components are a new drive shaft, coupling, and wiring diagram. The part number of the timer is 12-2371-01.

A new wiring diagram is on the back of this bulletin.

2. Bin Thermostat kit, part number **A37086-001**. This kit contains the necessary components to add a bin thermostat to a CD200 and CM³ combination. This lowers the ice level about 6" from the base of the ice machine. The part number of the reverse-acting thermostat in the kit is 11-0427-23.

These two kits can be retrofitted into any CD200 shipped prior to 8/9/96 that has a CM³ on top. Both kits must be used together to gain the maximum benefit.

CD200s built or shipped after 8/9/96 have the baffle, timer and bin thermostat bracket already installed. The bin thermostat itself and its related hardware are packed with the CD200.

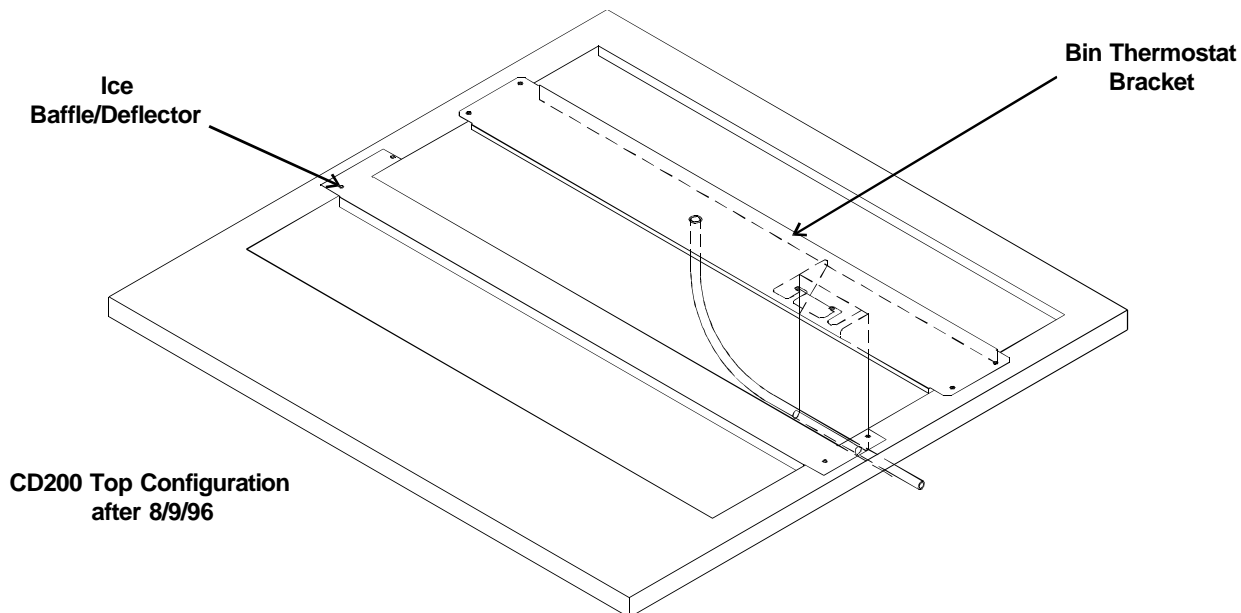

Other: A notch has been added to the ice chute hood safety switch mounting bracket to add clearance for the rubber bumper. If the safety switch does not close when the ice chute hood is up, the off-cycle agitation will not be working.

SERVICE BULLETIN

Subject: NME, FME, NSE, NDE and TDE550/650 Top Bearing Lubrication

Two parts have been made available as helpful aids to use when lubricating the top bearing.

1. **02-3559-01** is a needle that snaps onto a standard grease gun fitting. Use it to insert and deeply pack the proper lubricant into the top bearing.
2. **A36808-001** is a tube of the proper lubricant, also designed to fit a standard grease gun.

Both numbers are in the parts price list.

Needle, shown inserted into bearing

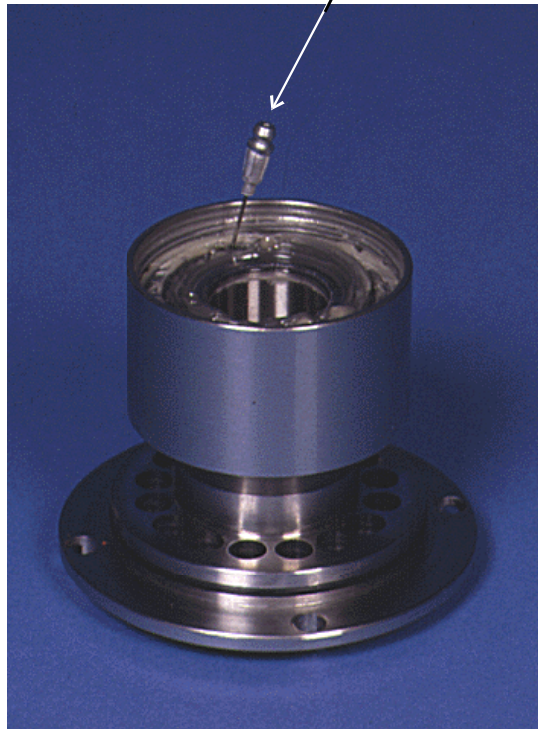

The logo for Scotsman, featuring the word "SCOTSMAN" in a bold, sans-serif font with a registered trademark symbol (®) to the right, all enclosed within a rounded rectangular border.

Bulletin Number: PS-16-96

Bulletin Date: October 1996

SERVICE BULLETIN

Subject: Change to SLD150

The design of the dispensing mechanism of the SLD150S-1 dispenser was changed in mid-1996. The changes included the addition of an off cycle agitation timer and a plexiglass door over the ice delivery area.

To **add** these parts to **prior** models, the following kits are available:

- Off cycle timer kit, PN C80570901. If the timer is installed, the door kit is required to contain the ice during agitation.
- Door kit, PN C80571702

New Model - October 1996

SLD150S-1B is a new model that replaces the SLD150S-1. The major changes include:

- New front panel, with plexiglass door
- New dispense rotor
- New dispense mechanism, including the door and solenoid from the IS220.
- Off cycle agitation timer added
- The coin kit is now KSLDC2, and the key kit is now KSLDK2.

SERVICE BULLETIN

Subject: CME1202 and CME1402 control circuit enhancement.

Beginning with May 1997 production (-11N), a thermostat and relay will have been added to all versions of the above two models. The benefit of this enhancement is that it greatly reduces the impact of ambient temperature changes - machines with this circuit will automatically adjust the harvest cycle length as needed to release all ice.

The thermostat and relay form the working components of a new circuit that, under certain low temperature conditions, by-passes the timer during the harvest cycle. The the timer still operates as it has, except when the low temperature conditions are present.

There is a kit available to add this part to any prior CME1202, CME1402, CMS1202 or CMS1402. The part number is: **A37281-020**.

How it works (refer to schematic diagram on the back):

When the unit is harvesting under low temperatures, the thermostat, sensing the inlet tube of the accumulator, will be closed. This connects power to the relay coil, which then closes contacts 7-4, which parallel and by-pass the plug-in finish relay contacts 9-3. When this happens the timer motor will stop at the end of its normal harvest time but the machine continues to harvest until the suction line temperature warms up and the thermostat opens, cutting power to the relay coil and breaking the by-pass circuit. In effect, this means that the timer always determines the MINIMUM harvest time, and, when conditions are cold, the new control circuit determines the MAXIMUM harvest time, which will vary as needed.

Under normal conditions the new circuit does not affect the machine at all.

Two service parts are available: The thermostat, its part number is: 11-0521-21 and it includes the clamps and screws needed to attach it to the suction line. The relay part number is 12-2070-04.

A schematic diagram of a single phase remote is on the back of this bulletin. Three phase will be similar.

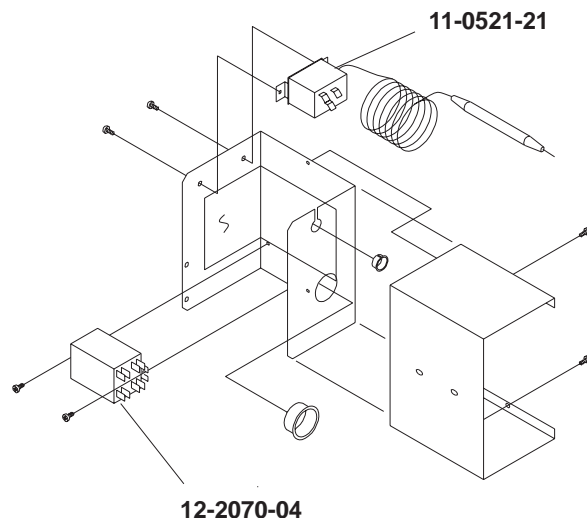

Kit Wiring Detail

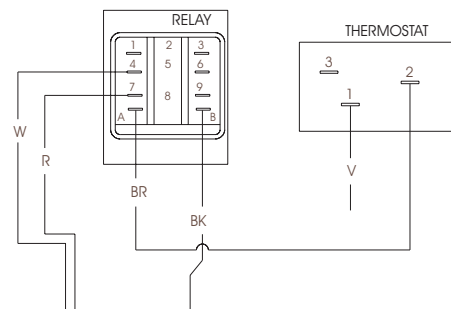

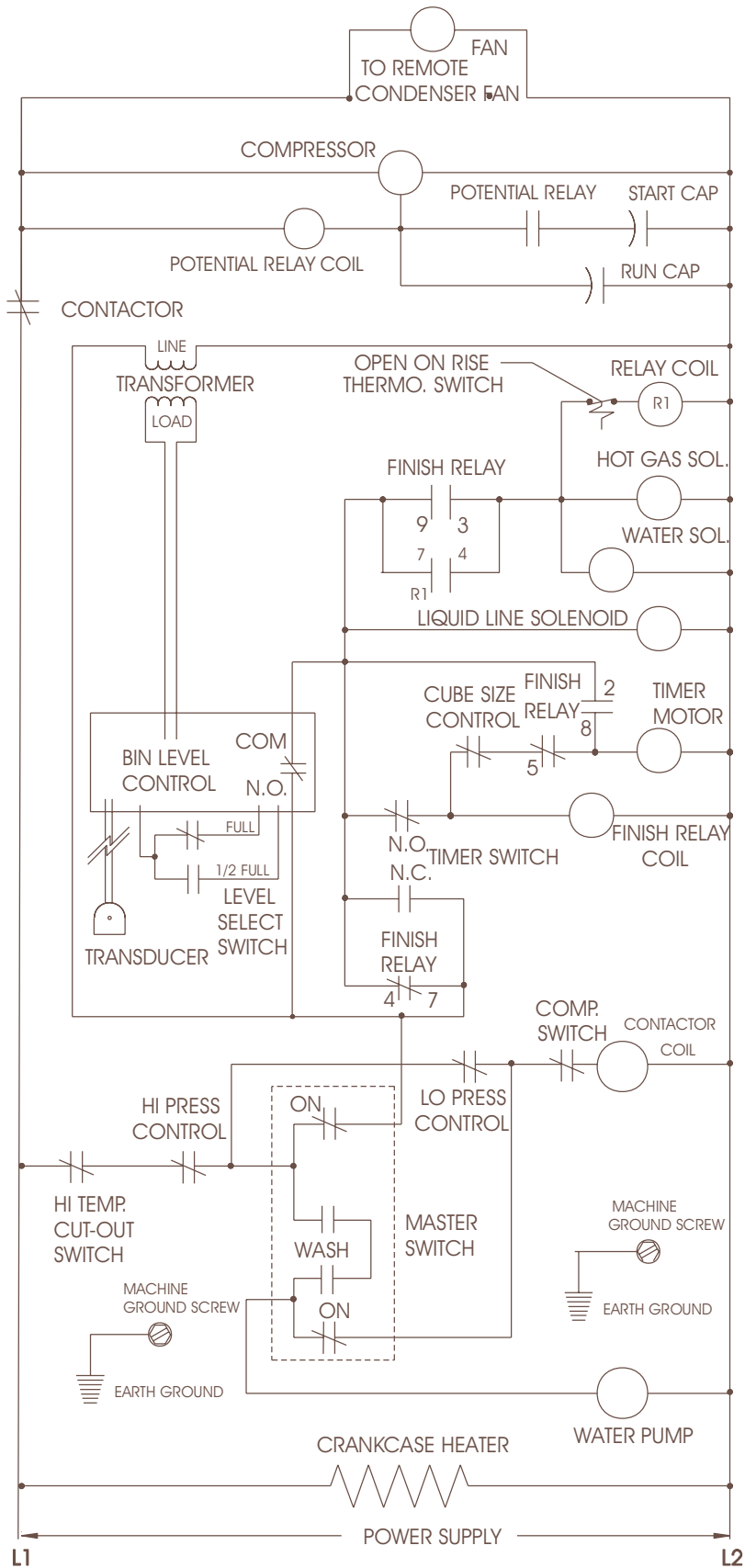

THIS UNIT SHOWN IN THE TIMED PORTION OF THE FREEZING CYCLE

SERVICE BULLETIN

Subject #1 : NDE550, NDE650, TDE550 and TDE650 Dispensing system.

Beginning with serial number date code -10N, the designs of the dispense drive motor and the dispensing vane have been improved, greatly increasing the strength of the assembly.

The engagement between the two is now a "double-D", meaning that there are two flats on the outside of the output shaft of the dispense drive motor. Because of this change they are NOT INTERCHANGEABLE with prior components.

Although the prior **vanes** are NO LONGER AVAILABLE, replacement drive **motors** to fit the PRIOR VANES are available, the part numbers are: 12-2407-22 (60 Hz) and 12-2407-27 (50 Hz).

Individual Part Number Reference:

	ND/NDE/TDE550	ND/NDE/TDE650	FD5 or FD6	HQD550 or HQD650
Drive Motor	12-2677-21 (60 Hz)	12-2677-21 (60 Hz)	12-2407-22 (60 Hz)	12-2407-22 (60 Hz)
	12-2677-26 (50 Hz)	12-2677-26 (50 Hz)	12-2407-27 (50 Hz)	12-2407-27 (50 Hz)
Vane	A37268-001	A37267-001	use existing inner bin	use existing inner bin

As a convenience, there is a kit available that contains BOTH the vane and the drive motor. It may be used in any prior ND, NDE or TDE 550 or 650 dispenser.

The vane & drive motor kit numbers are:

NDE/TDE550 60 Hz	NDE/TDE550 50 Hz	NDE/TDE650 60 Hz	NDE/TDE650 50 Hz
A37270-001	A37270-002	A37270-003	A37270-004

Note: The above kits should not be used on machines built after serial number date code -10N.

Subject #2: NDE Portion Control

Beginning with the same serial number as above, the portion control for dispensing has been deleted from the NDE550 and NDE650 dispenser. An optional kit is available to add portion control if specified by the user, the kit number is **KPC6/550**.

Beginning Serial Number Reference:

NDE650 - 008689-10N

NDE550 - 010699-10N

TDE650 - 008718-10N

TDE550 - 008386-10N

SERVICE BULLETIN**Subject: New Service Parts for AC55, CS55, AC125 and CS60**

The design of the legs for these models has changed. CS60s now ship with these legs. These new legs fit the prior models if all three parts are used.

A set of 4 complete is part number 0650670-00.

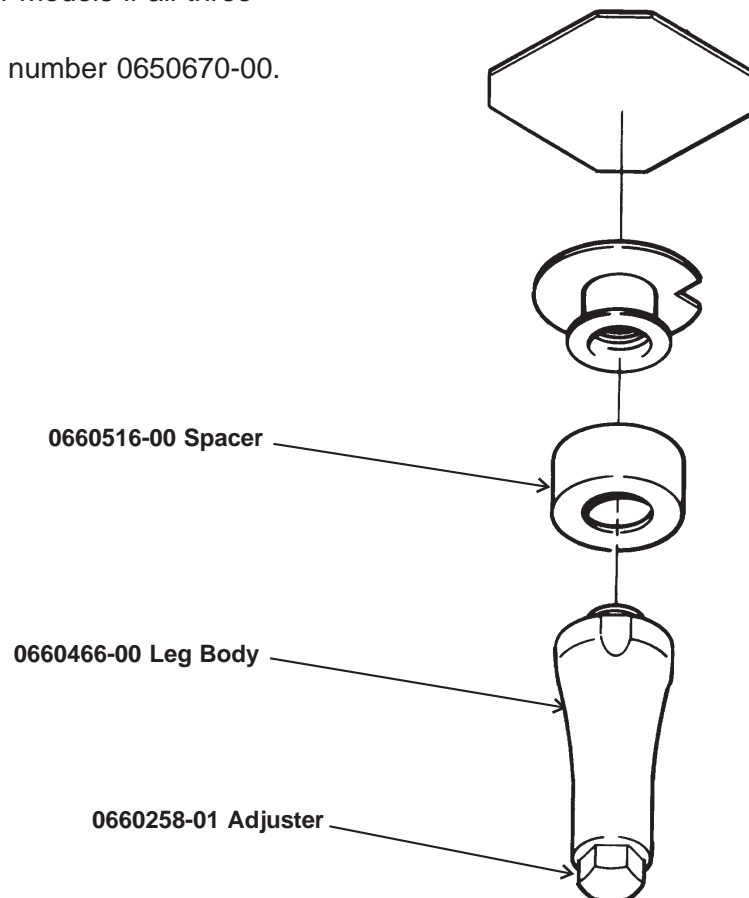

SERVICE BULLETIN

Subject: CSWE1 Compressor

The REPLACEMENT compressor for the CSWE1 has changed. The new compressor part number is: **04387773**. It is a complete kit that includes the starting components.

Replacement parts for this compressor are:

- 04387766 Relay and Overload Assembly
- 04387731 Terminal cover
- 04387764 Run capacitor
- 04387558 Mounting Grommet
- 04387559 Mounting sleeve

Note: Only the replacement compressor uses a run capacitor. That compressor uses the service parts listed above. The service part numbers for the original equipment compressor do not change.

To add the run capacitor when replacing a compressor:

On the compressor relay, one side has two quick connect posts.

- Connect the white wire to either one of the two posts on the side of the relay that has the two posts.
- Connect the Black wire to the overload.
- Connect wires between the run capacitor and the two open posts on the relay. Be sure the terminals are insulated.
- The run capacitor must also be mounted to the machine. Drill a small hole in the machine and secure the capacitor to the machine with a screw.

SERVICE BULLETIN

Subject: CD200 and CME256, CME506, CME656 (CM³) This bulletin supersedes PS-13-96

The design of the CD200 has been changed to make installation of a CM³ easier. The CD200 now includes a built-in thermostat and a wire harness to connect it to the CM³ ice machine.

The first serial number of a CD200 with the new configuration is 010542-10N. All CD200s with date code -11N (May 1997) and later have the new design.

The capillary tube of the thermostat is inside a stainless steel tube that runs from the front of the ice storage bin to the back.

The thermostat body is mounted to a bracket inside the CD200.

The thermostat part number is 11-0427-23.

The wire harness part number is 12-2694-01.

The two kits, Baffle & Timer kit, A37077-001; and Bin Thermostat kit, A37086-001 are still available for use when CM³ units are placed on CD200s that were mfg. prior to 8/9/96.

The new configuration cannot be retrofitted onto prior dispensers.

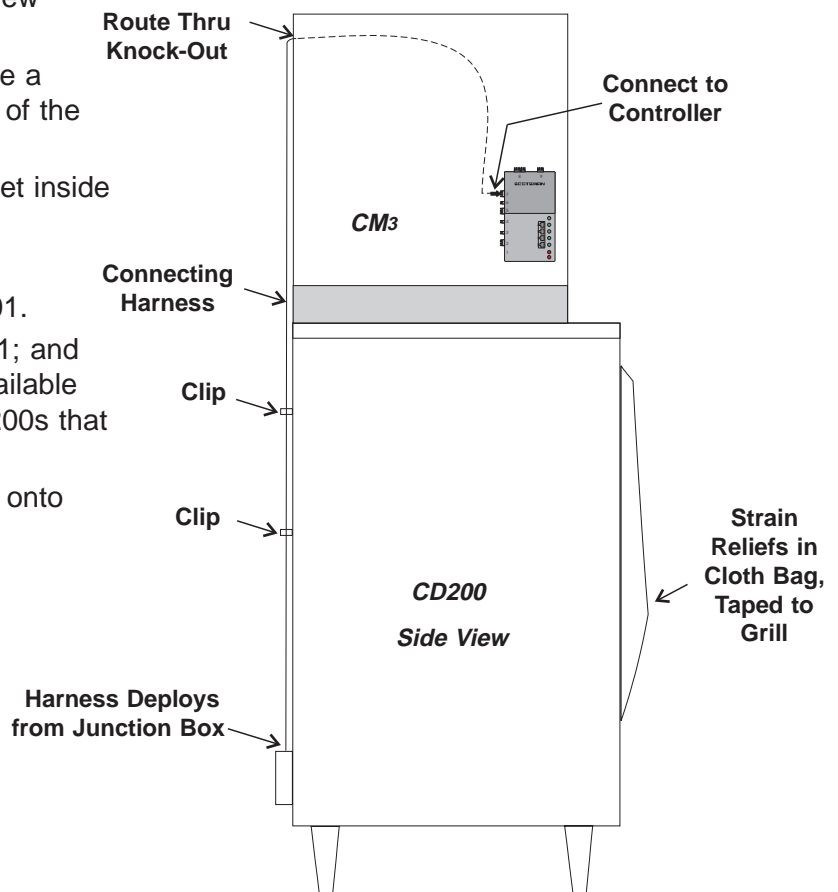

Side View of New Installation Configuration
for the Bin Control



SCOTSMAN

Bulletin Number: PS - 10 - 97

Bulletin Date: May 1997

SERVICE BULLETIN

Subject: SLE300 and SLE400 Hot Gas Valve

The hot gas valve has been changed. The part numbers to use are:

- for all 115 volt machines - **12-2417-21**
- for the SLE400R (208 - 230 volts) - **12-2417-23**

All SLE300s and SLE400s mfg. after date code 09N have the new hot gas valve.

This new valve body has a smaller port size and results in about 10 PSIG lower suction pressure during harvest. There is no change to the typical length of the harvest cycle.

From this point forward, only use the 12-2417 type hot gas valve on SLE300 or SLE400 cubers.

When changing an evaporator because of a refrigerant leak, replace the hot gas valve at the same time.

SERVICE BULLETIN

Subject: Various Changes

Several product changes have recently been made:

1. **Drain Fitting.** On many models the reservoir, overflow or bin drain fitting (casting) is now made of plastic. The new part number is: **02-3692-21** (includes mounting bolts), directly replacing the old part numbers of A31828-005 and A31757-001. Models affected include the AFE400, SCE170, NDE550/650 and TDE550/650.

2. **Flaker water inlet system.** The AFE400 flaker has changed from a copper inlet water line system to one made of plastic, similar to that used on SCE170, FDE470 and TDE470. Other models changing include: NSE650, NME650, NME950RL, NM952RL, FME1200RL, FM1202RL, NME950, FME1200, NME1250, FME1500, NME1850, FME2400, FME2400RL, NM1852RL and FM2402RL

3. **SLE300 and SLE400 top panel.** Since date code 08A, these two models use a single piece top panel. When stacking, a new kit, item number **KSSLE-22**, is required. The replacement top panel is part number **C80626501**.

4. **CD200s** no longer use the cube cutter, located to the right of the cube chute.

5. **RS160/220 and IS160/220.** Use the following for sweep arm part number identification: These parts are NOT cross-referenced.

Flaker Water System Parts

Inlet Fitting	Union Tee	Tubing - order by the foot	Male Connector
16-0835-01	16-1040-01	13-0895-01	16-1039-01

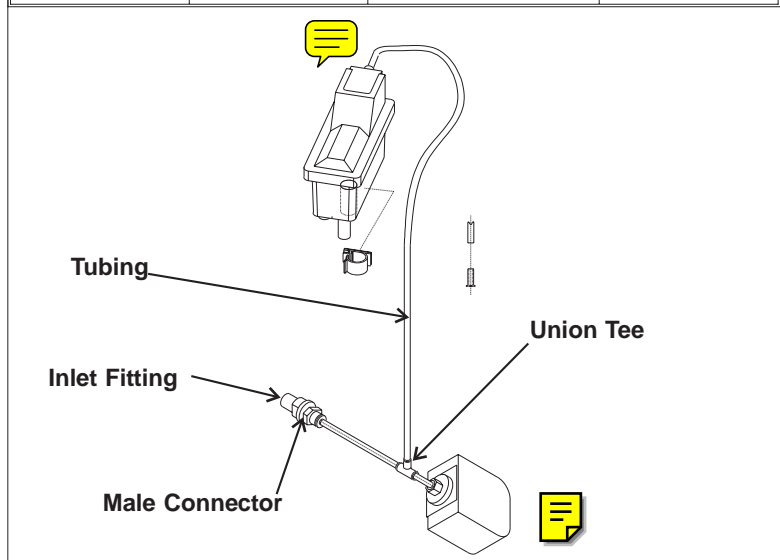

Model	Sweep Arm Part Number
RS160	A36846-001
RS220 or IS220	A36846-002
IS160	A36846-003

The logo for SCOTSMAN, featuring the word "SCOTSMAN" in a bold, sans-serif font with a registered trademark symbol (®) to the right, all enclosed within a rounded rectangular border.

Bulletin Number: PS - 1 - 98

Bulletin Date: January 1998

SERVICE BULLETIN

Subject: Contactors - Single Phase Only

Single phase contactor designs have been changed. The part numbers that change are:

- **12-2048-01** is changed to **12-2469-03** (115v coil, single phase)
- **12-2048-02** is changed to **12-2469-02** (230v coil, single phase)

Although different in appearance the new contactors are a direct replacement for the prior type. Models affected include:

- NDE550/650; FME1500/NME1250; TDE550/650; CME1202/1402; CME855/1000; CME865/1002; FME1200/NME950; SCE170; FME800/NME650; NDE750.

SCOTSMAN

Bulletin Number: PS - 3 - 98

Bulletin Date: Revised Nov. 1998

SERVICE BULLETIN

Subject: ERC301 Fan Motor

Effective with serial number 103236-10B, the ERC301 remote condenser is being manufactured with a one-third H.P. fan motor instead of the prior one-quarter H.P. motor.

The part number for the new motor is: **18-8797-32**.

Although the ERC301 is the only condenser manufactured with the one-third HP fan motor, the 18-8797-32 motor will be used as a common replacement for ERC151, ERC201, ERC302, ERC401, and ERC402 fan motors.

Note: Fan motors shipped and ERC301 condensers built after 11/1/98 have a shorter shaft. The fan blade mounts flush to the end on those motors. A quick check is that the "flats" on the motor shaft are now $1\frac{5}{8}$ " long and they were $2\frac{1}{2}$ " long. When the longer shaft one-third HP motor is used, position the fan blade $\frac{7}{8}$ " in from the end of the motor shaft.

SCOTSMAN

Bulletin Number: PS - 4 - 98

Bulletin Date: May 1998

SERVICE BULLETIN

Subject: CD200 Recycling Timer

Effective with serial numbers 098565-10B (CD200E-1B) and 099714-10B (CD200S-1B), the recycling timer has been changed to one that cycles every 3 hours.

The part number for the timer is **12-2431-01**, the harness for it is part number **12-2652-01**. Connecting the red wire of the timer to the harness and then connecting the black wire marked 3 hours to the terminal on the timer marked 6 minutes yields the 3 hour time.

To check if the timer is working, connect the red wire of the harness to the 6 minute terminal, in 6 minutes the timer should cycle the rotor. When it does, disconnect the red wire from the 6 minute terminal and connect the 3 hour wire to the 6 minute terminal. Do NOT use the 12 or 24 hour terminals.

The wiring diagram is on the back of this bulletin.

17-2579-1

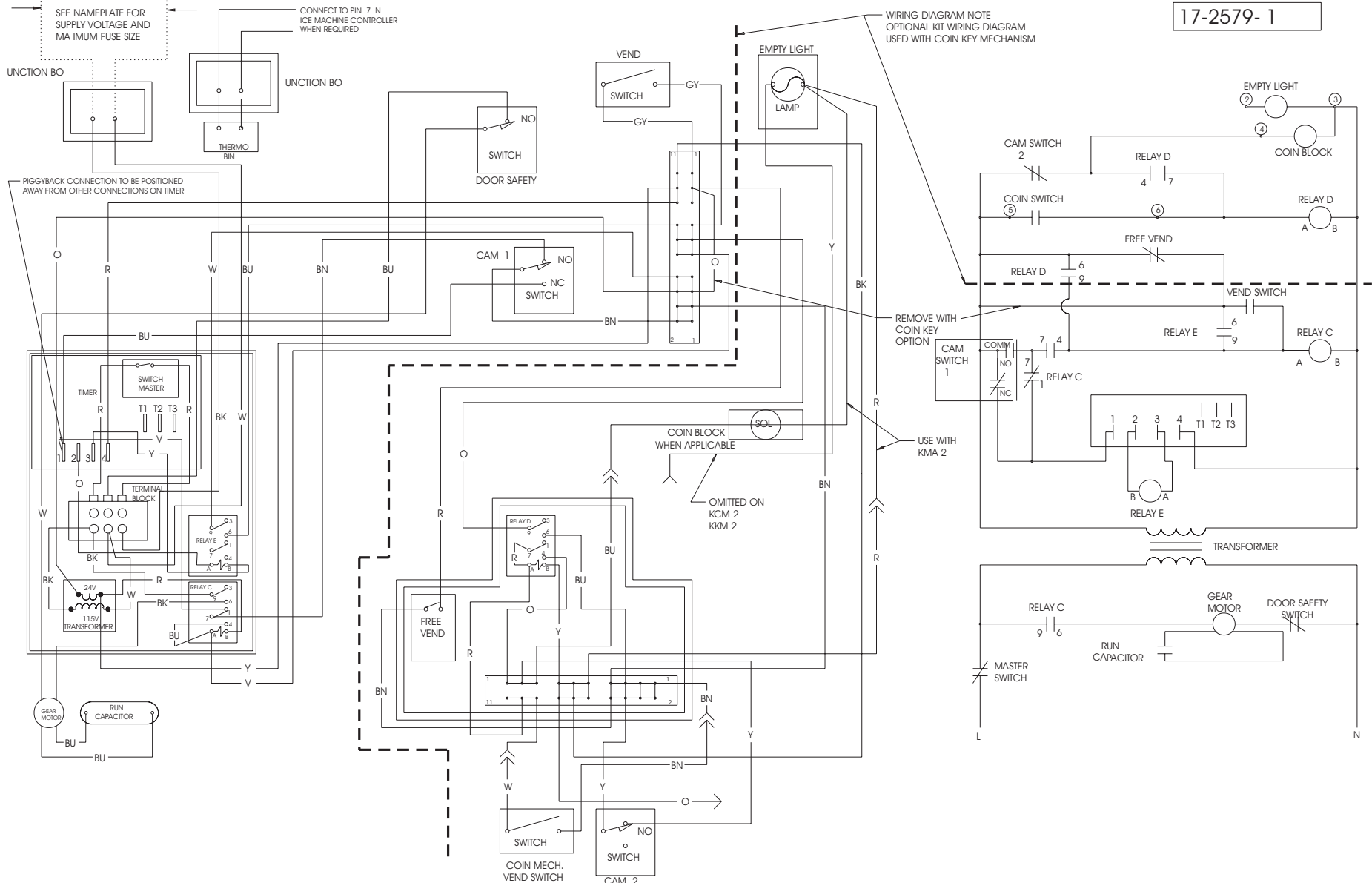

USE COPPER CONDUCTORS ONLY

THIS UNIT MUST BE GROUNDED



Bulletin Number: PS - 6 - 98

Bulletin Date: July 1998

SERVICE BULLETIN

Subject: Hot Gas Valve Coils

The Scotsman Parts Department now stocks **coils** for **Alco** hot gas valves.

Coil Part Number	Coil Voltage	Fits Alco Valves	Coils Used on Models
12-2719-21	120	12-2417-21, 12-2417-22, 11-0475-21	CME250, CME500, SCE170,
12-2719-22	240	12-2135-22, 11-0495-21, 12-2417-23, 11-0493-21, 11-0491-21	CME1402, CME1202, CME650, CME1002, CME855, CME865, CME1000,
12-2719-23	24	12-2471-21, 12-2471-22, 11-0507-21, 11-0507-22	CME256, CME506, CME656, SCE275, CME1356, CME1656,

SERVICE BULLETIN

Subject: SCE170 Control Module

The control module in the SCE170 has been **rotated** to improve wiring layout. Production of machines with the module rotated began with **July 1998** production. The first serial number is: 120714-12B. Additionally, the curtain's bottom edge has been cut back beginning with sn: 120790-12B.

Prior Layout
Wires are bundled together

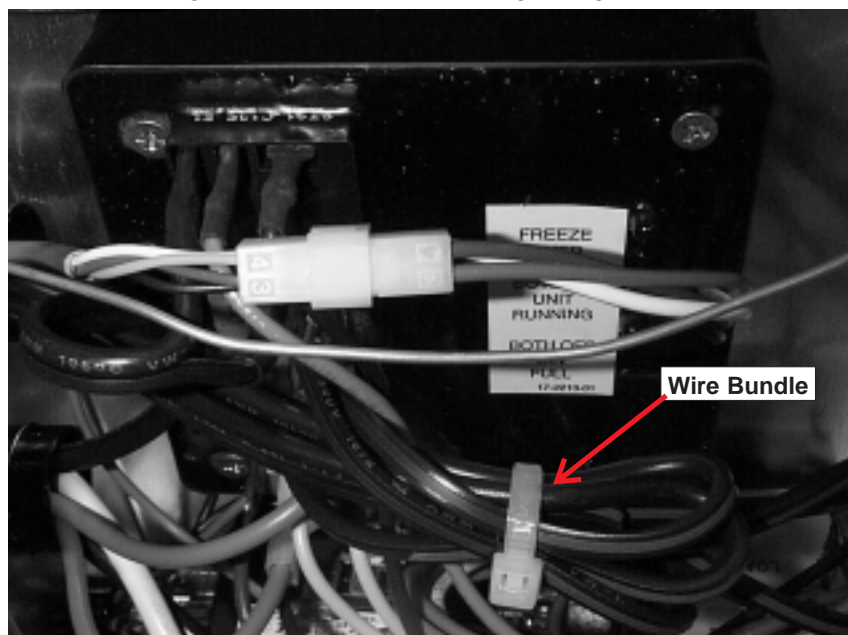

New Layout
Module is rotated and wires are separated into high and low voltage bundles.
This can be done in the field by cutting the cable ties, removing the four module mounting screws and rotating the module 90° counter-clockwise. Then remounted with the original screws. The wires should then be bundled as shown.

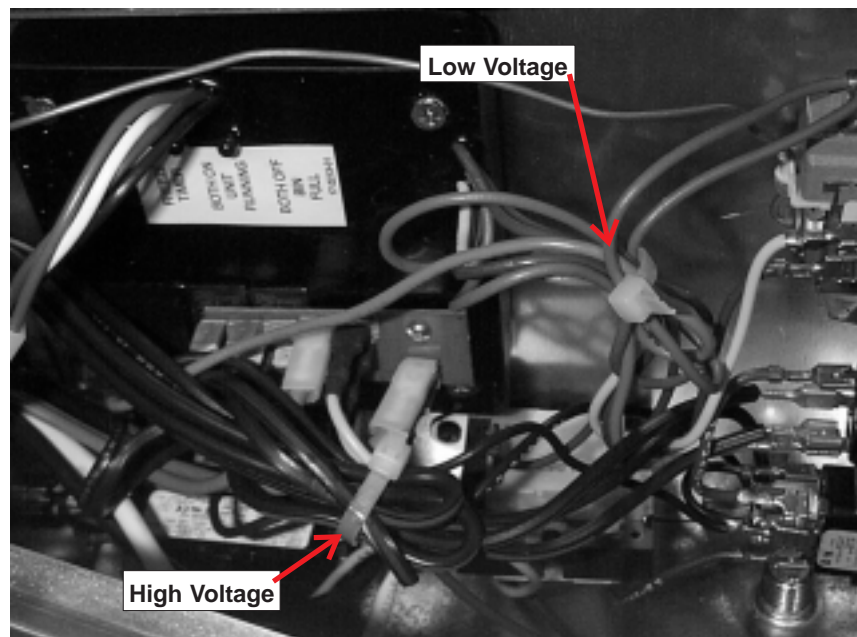

SERVICE BULLETIN

Subject: SSM Water Filter Service Parts

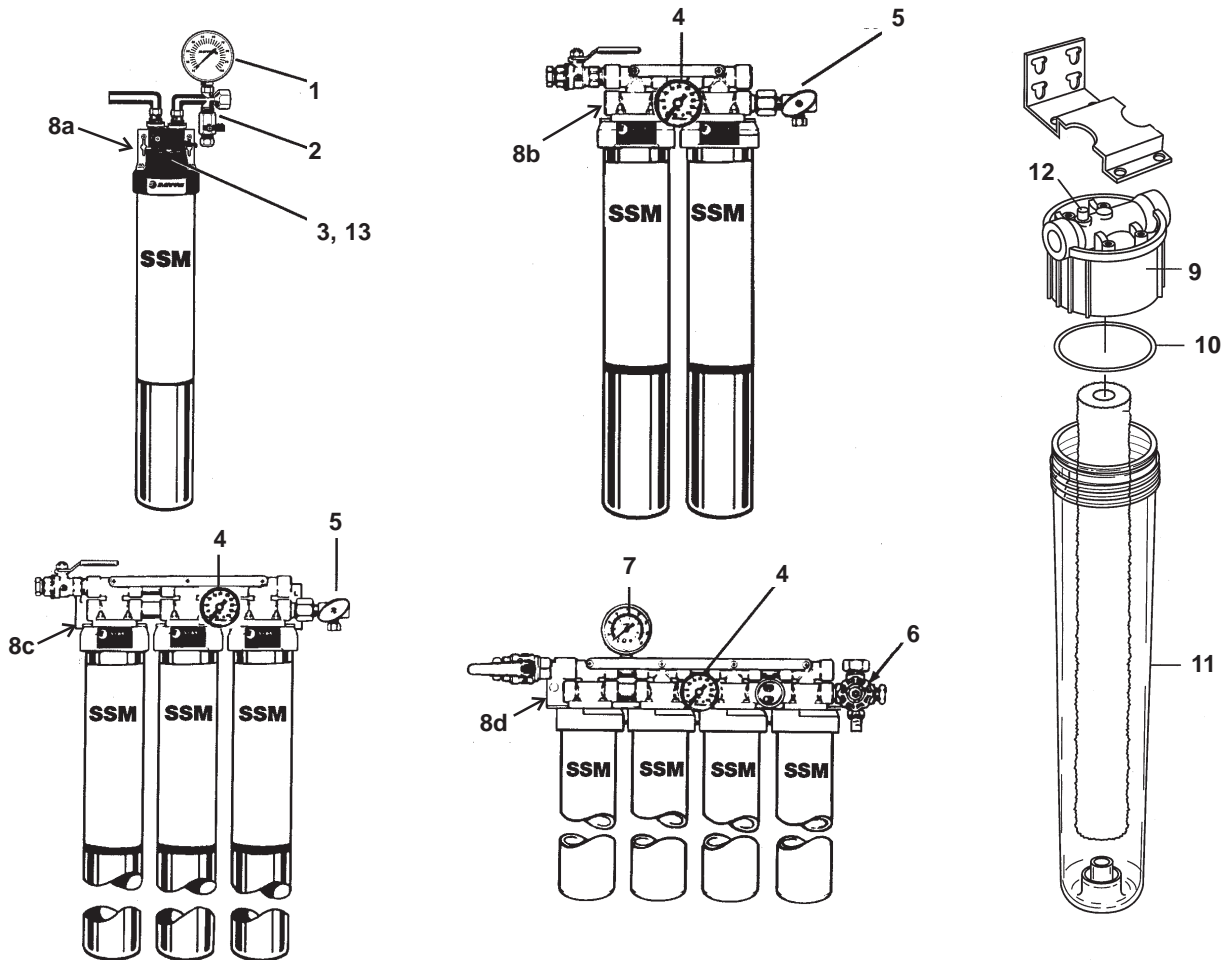

Item Number	Part Number	Description	Item Number	Part Number	Description
1	02-3790-15	Outlet gauge	8b	02-3790-02	Dual bracket
2	02-3790-16	Activation valve, single	8c	02-3790-03	Triple bracket
3	02-3790-12	Valve stem	8d	02-3790-04	Quad bracket
4	02-3790-14	Outlet gauge		02-3790-05	Screw for bracket
5	02-3790-17	Activation valve	9	02-2790-06	Prefilter head
6	02-3790-18	Activation valve, quad	10	02-3790-07	Ring seal
7	02-3790-13	Pressure gauge	11	02-3790-08	20" bowl
8a	02-3790-01	Single bracket		02-3790-09	10" bowl
			12	02-3790-10	Pressure relief kit
			13	02-3790-11	Valve handle

SCOTSMAN®

Bulletin Number: PS - 9 - 98

Bulletin Date: September 1998

SERVICE BULLETIN

Subject: CME865R and CME1002R high pressure cut out switch change.

Beginning with serial numbers ending in -02B (August 1998 production), the high pressure cut out (also called the high pressure control) has been changed from a manual reset to an automatic reset.

When replacing a defective high pressure cut out on these two models, replace the old switch (part number 11-0485-21 - cut out at 450 PSIG), with the **new** switch, part number **11-0501-22** (cut out at 450 PSIG, cut in at 350 PSIG).

The new cut out connects to the machine's wiring in the same place as the original's. Also, part number 11-0485-21 will continue to be used as a service part for other products.

SCOTSMAN

Bulletin Number: PS - 10 - 98

Bulletin Date: October 1998

SERVICE BULLETIN

Subject: SCE170 Air Cooled High Pressure Cut Out Change

Beginning with serial numbers ending in -04B (October 1998 production), the high pressure cut out (also called the high pressure control) has been changed from a manual reset to an **automatic reset**.

When replacing a defective high pressure cut out on an air cooled SCE170, replace the old switch (part number 11-0485-22 - cut out at 450 PSIG), with the **new** switch, part number **11-0501-22** (cut out at 450 PSIG, cut in at 350 PSIG).

Although the new cut out connects to the machine's wiring in the same place as the original's, when replacing a manual reset cut out, quick connects will have to be added to the existing wires so they can be plugged onto the new switch. Also, part number 11-0485-22 will continue to be used as a service part for other products.

SERVICE BULLETIN

Subject: New Service Part

Models Affected: CD200

Details:

The replacement vend switch for the CD200 has been changed. The new part number is: **A37477-021**. All orders for the prior switch, pn 12-1878-02, will be changed to the new switch. The new switch is very similar to that used in the HD356, and is complete with a mounting plate. Connect the wires to COM and NO.

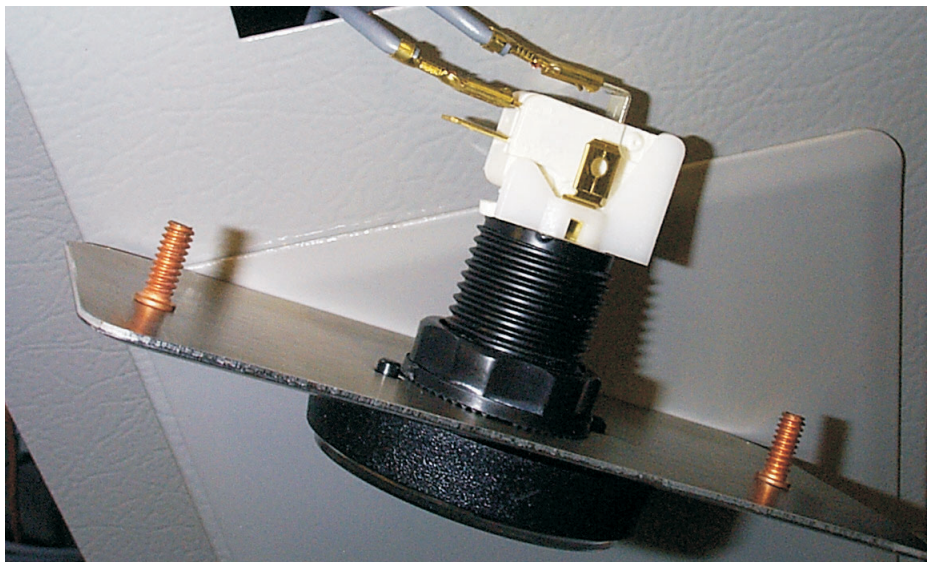

SERVICE BULLETIN

Subject: New Service Part

Models Affected: CME1356A and CME1656A (air cooled only)

Details:

A small sheet metal cover, pn **A37480-001**, has been added to these two models. It is located just above the electrical connections to the controller.

The purpose of this cover is to keep airborne moisture from collecting on the wire harnesses. Use began with February 1999 production (date code -08P and up).

A37480-001 Cover





Bulletin Number: PS - 6 - 99
Bulletin Date: August 1999

SERVICE BULLETIN

Subject: Refrigeration Solenoid Valve Strainers

Strainers have been added to all Scotsman CM³ type cubers. They are separate parts that are located on the inlet side of the hot gas and harvest bypass solenoid valves. In some air cooled units they are a change from hot gas valve filters, in all other models they have been added to the systems.

The part numbers are:

Inlet Size (ID)	Outlet Size (ID)	Strainer Part Number	Used On
¼ "	same	16-1063-02	CME256
⅜ "	same	16-1063-01	CME506, CME656, CME806
½ "	same	16-1063-03	CME1356, CME1656, CME2006

Production of this change in the above cubers began in August. Starting Serial Numbers are:

CME656AE-32C	229915-02P
CME506AE-1C	230160-02P
CME656AE-6C	232505-02P
CME656WE-32C	232511-02P
CME506RE-1C	232503-02P
CME256AE-1C	230110-02P



Bulletin Number: PS - 7 - 99
Bulletin Date: August 1999

SERVICE BULLETIN

Subject: NME950R, FME1200R, NME1850R and FME2400R

The above remote condenser flakers have had a refrigeration system change. An accumulator has been added to them. There was no change to refrigerant charge or superheat.

The part number of the accumulator is: **16-0778-01**.

Production of these machines with an accumulator began in July 1999.

The starting serial numbers are:

NME950RE-32A

212771-12P

FME2400RE-32A

212906-12P

All NME950R, FME1200R, NME1850R and FME2400R produced July 1999 (-01P) and later have the accumulator.

SERVICE BULLETIN

Subject: HD356C, BH550C, BH800C and BH900C

The above models are being manufactured as a "C" series. They are easily identified because their front vertical corners are rounded.

The service part numbers (all stainless steel) that change are:

HD356 C Left Side Panel: A37638-001

HD356 C Right Side Panel - push button: A37637-002

HD356 C Right Side Panel - for coin or card units: A37637-001

HD356 C Top Panel (plastic): 02-3839-01

BH550C Door Frame Kit: A37639-020

BH800C Door Frame Kit: A37640-020

BH900C Door Frame Kit: A37641-020

SERVICE BULLETIN

SUBJECT: ERC101, ERC201, ERC402, ERC151 and ERC302 Installations

The above ERC remote condensers are no longer approved for new installations where they would be mounted on their ends (tubing connections at the top).

ERC311, ERC411 and ERC611 limitations remain as they were.

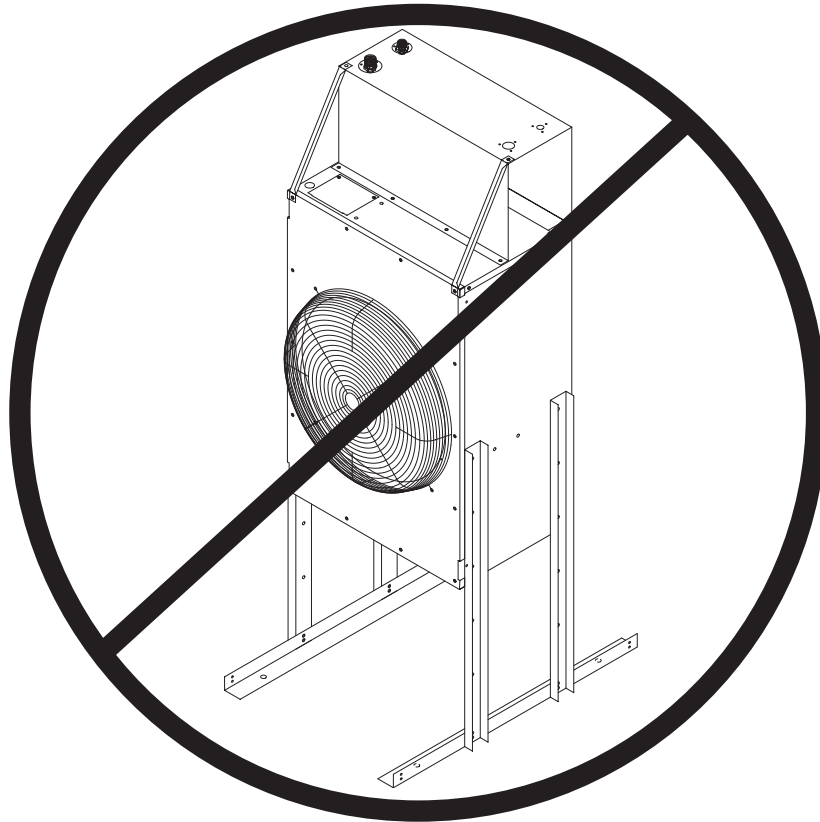

SERVICE BULLETIN

Subject: Various Changes

1. The ¼ HP Gear Case Cover, Gear Case Kit and Complete Gear Reducer have had a design change to the input shaft area. Instead of a lip seal, a labyrinth-type seal is now part of the gear case cover (only on the input or motor end). The part numbers remain the same.
2. TDE550 and TDE650. An internal cover has been added, positioned inside the splash panel, behind the Touch Free sensors. It consists of foam insulation and acts as a barrier to external contamination. The starting serial number of a TDE with the foam insulation is: 266638-07C. The part number of the foam insulation is: **19-0599-05**.
3. AFE400 bin thermostat bracket change. The tube used to hold the bin thermostat capillary tube has been changed to yield more precise control of the off-cycle. The new part number is **13-0895-01**. This is ¼ inch OD plastic tubing, each AFE400 requires 9" of it. Scotsman sells plastic tubing like this by the foot.
4. Bin gasket material (19-0503-04) has changed color from white to black.

SERVICE BULLETIN

Subject: Flaker Drip Pan Change

The replacement Drip Pan for all NM/NME and FM/FME models has been changed. The new part number is: **A37705-021**. This is a kit that includes:

- New plastic drip pan

- Cork gasket

- Three different rubber drain hoses, one for all 21" wide and the right side of 42" wide units, one for all 30" wide units and one for the left side of 42" wide units. The service technician simply selects the correct hose from the kit when installing it.

The change improves the ability of the above flaker's drain system to route water away from the gear reducer and evaporator assembly, reducing the possibility of water infiltration into the gear reducer.

SERVICE BULLETIN

Subject: Model Change. The following modular cubers have had a model series change:

CME1356 from a "B" to a "C"

CME1656 from a "B" to a "C"

CME2006 from a "B" to a "C"

The change is to the top panel. The new panel is **plastic** and will **only fit C series and higher** machines. The part number is: **02-3823-21**.

The prior panels will still be available for use as service parts on A and B series machines.

SERVICE BULLETIN

Subject: Model Series Revision

The following cubers have had a model series revision:

CME256 from "C" to "D"

CME506 from "C" to "D"

CME656 from "C" to "D"

CME806 from "C" to "D"

For example, the CME256AS-1**C** is now CME256AS-1**D**.

The change to the "D" series is due to a change to a new compressor starting device (a PTCR), and a related controller change. Production began with date code 10C.

PTCR and Controller Change

The PTCR (Positive Temperature Coefficient Resistor) replaces the start capacitor and potential relay in the above D series single phase machines. The part number for the PTCR is **18-8835-01**.

The unique starting characteristics of a PTCR requires a controller that is programed to work with them. That new controller's part number is **A37703-021**.

Controller Applications:

The only correct replacement controller for the **D** series (with PTCR) is the A37703-021. However, this part will work in any **CME256-806**, and is the **replacement controller for CME256 through CME806, replacing the 12-2543-21**.

The 12-2543-21 controller will no longer be produced, however existing parts may still be used on any A - C series machines.

Replacement single phase compressors for the above models now include a PTCR along with the prior starting components. Note: Due to the controller, a PTCR cannot be used on the A through C series machines, the original design start capacitor and relay must continue to be used.

PTCR Technical Details:

The PTCR is wired in series with the compressor's start winding and in parallel with the run capacitor. Before the compressor starts, the resistance of the PTCR is relatively low, and current flows to the start winding. As the current flows the PTCR's temperature increases. When it reaches a certain point, the resistance of the PTCR increases dramatically and current flow to the start winding stops. At this point the compressor has started. The PTCR normally operates at about 180°F. One characteristic of a PTCRs operation is that when starting it MUST be relatively cool (less than 120°F.) or the compressor may not restart. It will typically take about 5 minutes after a shut down before the PTCR is cool enough to restart the compressor.

The Service Manual for the above machines has also changed part numbers to the following:

Part Number **17-2764-01**: Covers all series of air and water cooled CME256, CME506, CME656 and CME806.

Part Number **17-2765-01**: Covers all series of remote air cooled CME506R, CME656R and CME806R.

SERVICE BULLETIN

Subject: CME256, 506, 656, 806, 1056 Panel Change.

The top panel material of the above machines has been changed from stainless steel to grey plastic. The plastic top panel's part number is: **02-3822-21**. This is a complete top panel that fits **all** CME256-806, from the A through the D series.

The top panel for the CME1056 has also changed to grey plastic. Its part number is **02-3822-22**.

Production of the CME256, 506, 656, 806 and CME1056 with plastic top panels began in June 2000.

SERVICE BULLETIN

Subject: CSW45PA Drain Hose Change

The drain discharge hose for the CSW45 Drain Pump model has been changed. The original hose was clear tygon, the new one is made of braided material, similar to beverage tubing.

The new part number is **02208432**.

SERVICE BULLETIN

Subject: New Flaker Control Board

The replacement control board for all NM/NME, FM/FME, NS/NSE, ND/NDE and the FDE470 has been changed.

The new replacement control board kit includes a new water sensor probe and the wire harnesses used to connect the control board to the existing wiring. The part number is: **A37750-021**.

Technical Changes:

The water sensor probe used with this board is new - the prior water sensor probe (A33101-022, still available for use with the prior board) cannot be used with this control board and the water sensor probe that comes with the new board cannot be used with the prior control board.

Scotsman's Flaker Board Tester (A33942-001) can still be used to test the ice level sensor circuit. Although the water level sensor circuit cannot be checked with the Tester, the new sensor is a conductivity probe that is easy to diagnose. See diagnostics on the back of this bulletin.

The new control board has several new features:

- Lights indicating when the compressor or auger relay is powered.

- Auger drive motor load sensor system

- Auger drive motor indicator light

- Automatic restart attempts after an auger motor overload condition

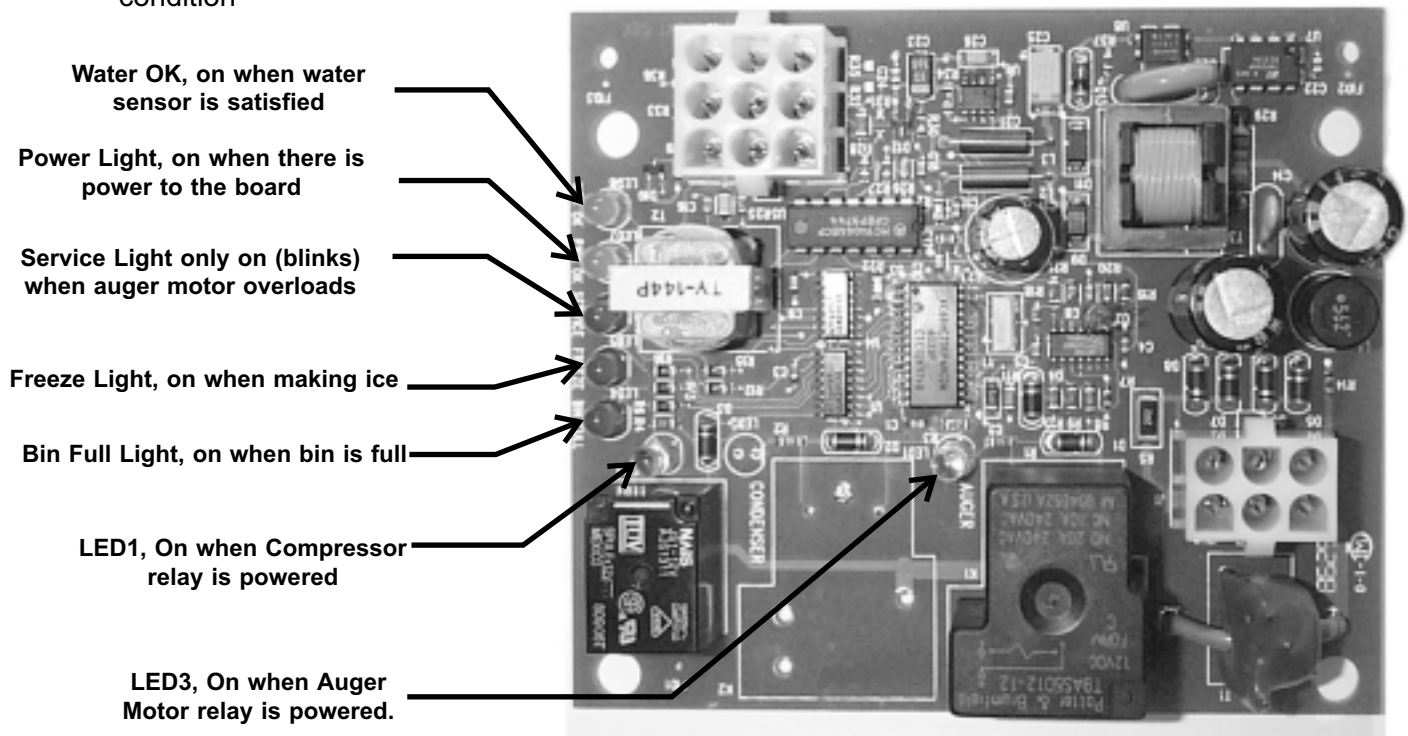

Controller Diagnostic Chart

Indicator Light	Light is ON	Light is Blinking	Light is OFF
WTR-OK	Water in reservoir	Shutting down due to No Water	No water in reservoir
PWR-OK	Power to controller AND controller functional	Controller malfunction	No power to controller OR controller failed
Service	Restart failed ¹	Attempting restart ²	Normal operation
Freeze	In ice making mode	Waiting to start ³	Not in ice making mode
Bin Full	Ice sensors blocked ⁴	Shutting down due to a Full Bin	Bin is not full
LED1 or LED3	Relay coil powered	-	Relay coil not powered

1. Auger motor current was excessive on successive restart attempts.
2. Auger motor current is excessive but restart sequence has not been completed.
3. Compressor must be off for at least 2 minutes before the controller will restart it.
4. Ice sensors must be blocked for at least 6 seconds before the bin is assumed to be full.

Water Sensor Diagnostics

The water sensor used with this control board is a conductivity probe. If there is water in the reservoir, and the Power OK light is on, but the Water OK light is NOT ON:

1. Pull water sensor probe out of the reservoir and check the tip - if dirty wipe it with a clean cloth and return it to the water reservoir. Within about 15 seconds the Water OK light should go ON, if it does not:
2. Pull the water sensor probe out of the reservoir and touch the tip to an unpainted surface of the ice machine's chassis. The Water OK light should go ON, if not:
3. Disconnect the water sensor probe from the its wire harness and insert a copper wire into the harness where the probe was connected. Touch the wire to an unpainted surface of the ice machine's chassis. If the Water OK light glows, replace the water level sensor (pn 12-2760-21). If the Water OK light does not glow, replace the control board.

To Reset the Board:

Disconnect and reconnect power to the board - at the machine's power supply.

SERVICE BULLETIN

Subject: Bin Thermostat Kit for CME256, CME506, CME656 and CME806

A kit is now available to install a bin thermostat on the above models. The kit number is: **A37749-001**.

The kit consists of a thermostat, brackets, tubing and a wire harness. It also includes a special harness that must be used when stacking two of these machines.

The above listed models use their ice sensors to control the level of ice in the bin. This typically results in a very full bin, maximizing the amount of ice available for a user. In some cases a user may not want that much ice. Use of this thermostat kit will lower the peak ice level about 8 inches at the ice drop area.

The kit fits most of the bins these machines are used on. For example it can be used on an HTB555 or a BH550. It also fits a BH800 or a BH900 when they are used with the normal bin top adapter. Another application would be when recycling a used bin that does not have a long enough baffle.

This kit is not recommended for use with a dispenser. Use on an HTB250 will only let the bin fill about $\frac{1}{2}$ full, and is not recommended. Using it on an HTB350 will result in a bin that is about two-thirds full of ice when the machine shuts off.

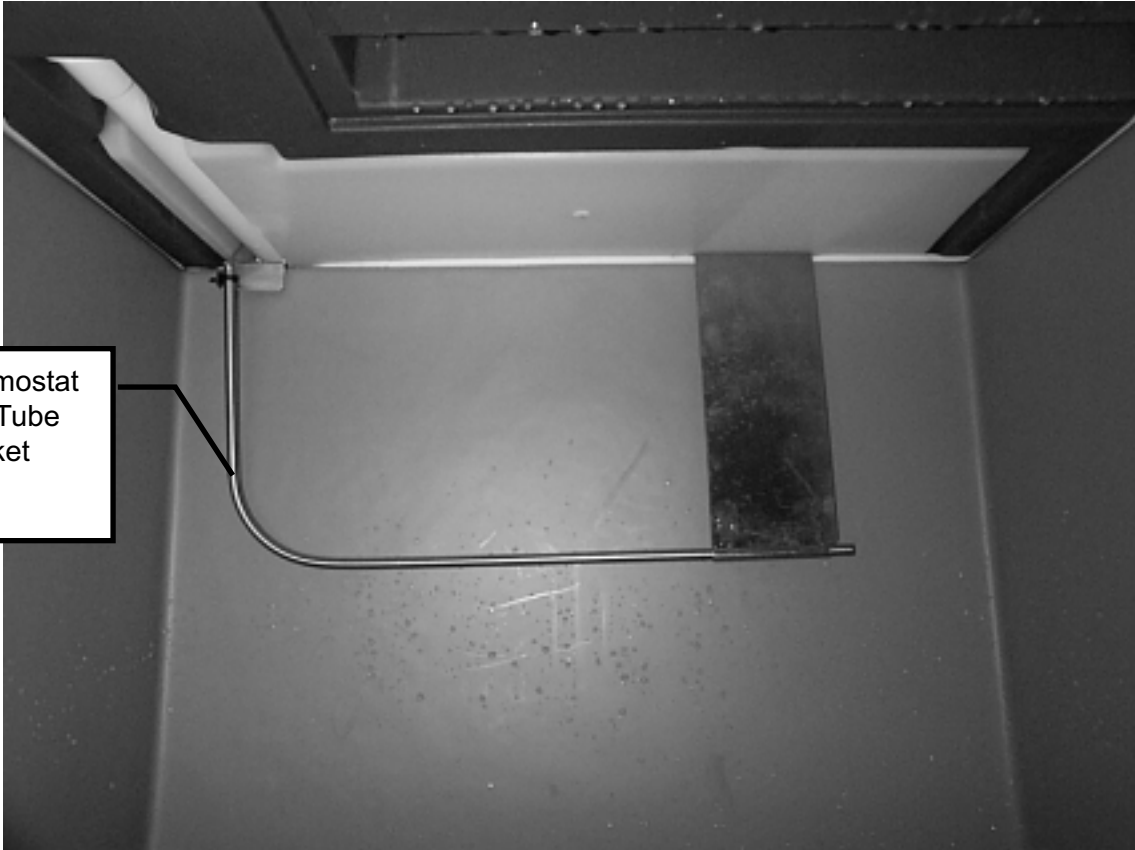

Thermostat
Cap Tube
Bracket

SERVICE BULLETIN

Subject: Model Series Revision

The following cubers have had a model series revision:

CME1056 from "A" to "D"

For example, the CME1056AS-32A is now CME1056AS-32D.

The change to the "D" series is due to a change to a new compressor starting device (a PTCR), and a related controller change. Production began with date code 03C.

PTCR and Controller Change

The PTCR (Positive Temperature Coefficient Resistor) replaces the start capacitor and potential relay in the above D series single phase machines. The part number for the PTCR is **18-8835-01**.

The unique starting characteristics of a PTCR requires a controller that is programmed to work with them. That new controller's part number is **A37703-026**.

Controller Applications:

The only correct replacement controller for the **D** series (with PTCR) is the A37703-026. However, this part will work in any CME1056, and is the **replacement controller for the CME1056, replacing the 12-2727-21**.

The 12-2727-21 controller will no longer be produced, however existing parts may still be used on any A series CME1056 machines.

Replacement single phase compressors for the above models now include a PTCR along with the prior starting components. Note: Due to the controller, a PTCR cannot be used on the A series machines, the original design start capacitor and relay must continue to be used.

The service manuals have also changed.

CME1056 service manual is 17-2796-01

CME1056R service manual is 17-2797-01

SERVICE BULLETIN

Subject: Model Series Revision

The following cubers have had a model series revision:

CME1356 from "C" to "D"

CME1656 from "C" to "D"

For example, the CME1356AS-32**C** is now CME1356AS-32**D**.

The change to the "D" series is due to a change to a new compressor starting device (a PTCR), and a related controller change. Production began with date code 03C.

PTCR and Controller Change

The PTCR (Positive Temperature Coefficient Resistor) replaces the start capacitor and potential relay in the above D series single phase machines. The part number for the PTCR is **18-8840-01**.

The unique starting characteristics of a PTCR requires a controller that is programed to work with them. That new controller's part number is **A37703-023**.

Controller Applications:

The only correct replacement controller for the **D** series (with PTCR) is the A37703-023. However, this part will work in any CME1356-1656, and is the **replacement controller for CME1356 and CME1656, replacing the 12-2656-21**.

The 12-2656-21 controller will no longer be produced, however existing parts may still be used on any CME1356 or CME1656 A - C series machines.

Replacement single phase compressors for the above models now include a PTCR along with the prior starting components. Note: Due to the controller, a PTCR cannot be used on the A through C series machines, the original design start capacitor and relay must continue to be used.

The service manuals have also changed

CME1356 and CME1656 service manual is 17-2792-01

CME1356R and CME1656R service manual is 17-2793-01

SERVICE BULLETIN

Subject: New Ice Storage Bins

The BH260 and BH375 replace the very similar SLB260 and SLB375.

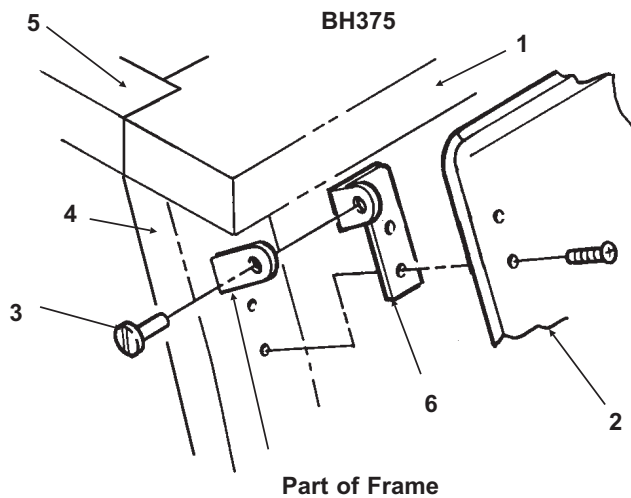

Item Number	Part Number	Description
1	C80211705	Canopy
2	C80230902	Bin door assembly
3	C80206901	Hinge pin
4	C80209504	Door frame assembly (includes hinge)
5	19-0503-04	Gasket tape, 90"
6	C80206601	Hinge for door, rt.
	C80206602	Hinge for door, left
Not illustrated:		
6	C80399201	Clear button
7	C80511301	Baffle
8	C35926400	Thumbscrew

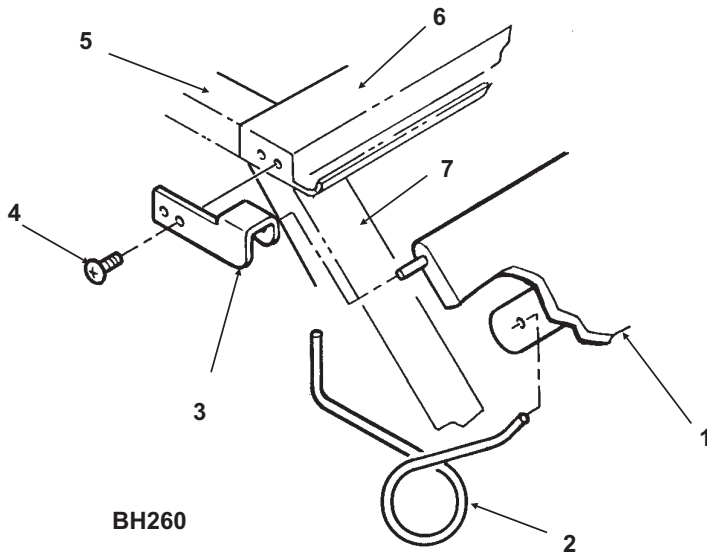

Item Number	Part Number	Description
1	C19475304	Door Assembly
2	C19629100	Door spring
3	C80299602	Left door hinge
	C80299601	Right door hinge
4	C19632604	Hinge pin
5	19-0503-04	Gasket tape, 90"
6	C80307602	Canopy
7	C80309002	Door frame assy

Drain Parts:

BH375 and BH260

- Female fitting, pn C80205501
- Male fitting, pn C80205301
- Flanged hex nut, pn C80205401

Leg Set is KLP2E

SERVICE BULLETIN

Subject: SCE170 B Series

The SCE170 has had a model series revision. The new models are SCE170A-1B and SCE170W-1B. The changes are in the refrigeration system and include a new compressor.

New Parts for the B series:

Compressor Kit	A37824-021
Start Capacitor	18-8831-29
Relay	18-8831-28
Overload	18-8831-27
Air Cooled Condenser.....	18-8844-01
Water Cooled Condenser.....	18-3303-02
Thermostatic Expansion Valve.....	16-0868-22

The A37824-021 compressor kit (Tecumseh) replaces the prior Copeland compressor, which is no longer available. The kit includes the new compressor (plus relay, capacitor, overload and a drier) and the necessary tubing to connect it to the refrigeration system of the A series. Refer to the instructions that are included with the kit for detailed information.

The B series refrigerant charge has changed from the A series:

Air cooled B series is 16 ounces

Water cooled B series is 11 ounces, both remain R-404A.

SERVICE BULLETIN

Subject: Insulation Change

Applications: Modular Flakers, models NME654 and up.

The insulation for the upper end of the NME/FME evaporator has been changed. The removable styrofoam parts have been replaced with closed cell foam components to increase efficiency and improve serviceability.

The ice chute body now comes with foam insulation applied to it, replacing the two styrofoam halves (A32693-001 and A32693-002) that had been held in place with the plastic strap.

Ice Chute Body with insulation: 02-3841-01

An insulation collar has been added to the space between the lower chute and the top of the evaporator. There is one collar (it looks like a big donut) for FME models and a different one for the nugget machines. The donut replaces the styrofoam insulation inside collar (pn A33102-001)

FME (flaked) collar: 13-0929-01

NME (nugget) collar: 13-0929-02

Production of machines with this design began with date code -04C.

These changes do NOT apply to the nugget dispensers or the NSE model.

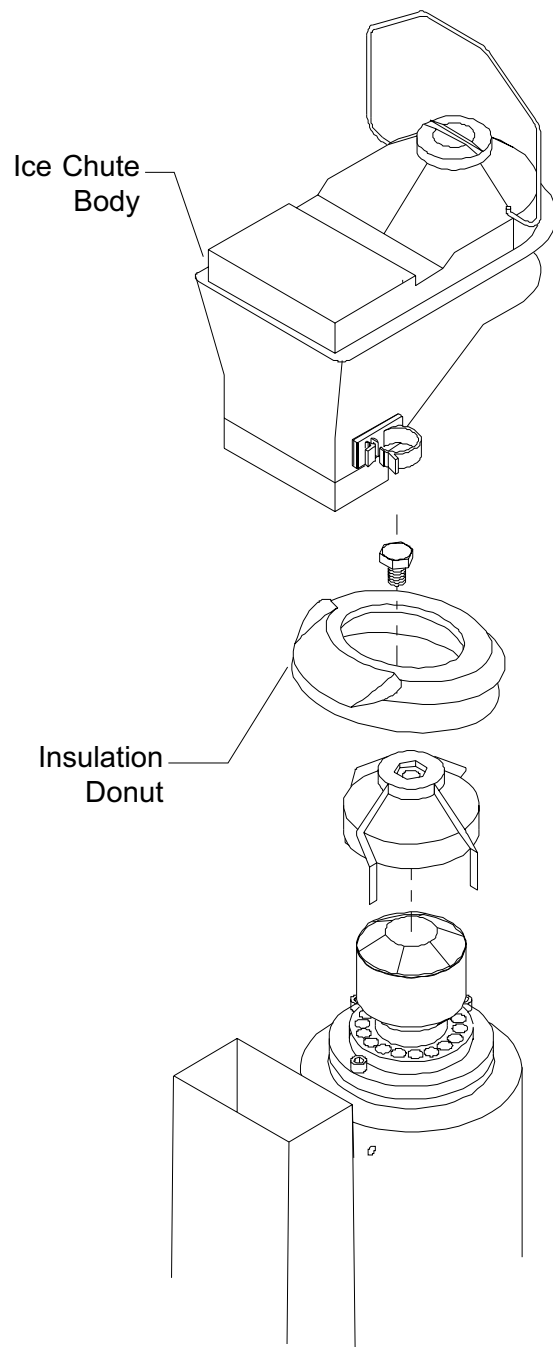

SERVICE BULLETIN

Subject: Legs & Casters

Scotsman leg kits, KLP2E, KLP7, and KLP2S, caster kits KSLBC2, KBC1, KBC20, KBC8 and KBC9 all have the same thread size: **5/8 - 11**.

Nearly all Scotsman bins and machines with storage have the same leg thread size too: **5/8 - 11**.

This includes:



SCE cubers

AFE flakers

NSE nugget flaker

BH bins

HTB bins

SLB bins

HD, SLD and CD dispensers. Flanged-foot legs (KLP7) included with HD356.

DMS machine stands

Exceptions:

CS60, CS55, AC125 and similar.

CSW45, CSWE1 and similar

IS/RS dispensers (thread size 3/8 - 16) use KLP5 leg kit

Consumer machines like the DCE33.

B530, BH1351, BH1352, BH1360 and similar prior bins. See each bin's individual parts list.

Caster Applications:

KBC1 fits all that accept 5/8 - 11 legs, but should not be used with an HTB bin.

KBC20 is designed for HTB bins.

KBC8 (for BH550) and KBC9 (for BH900) are used to raise the bin height when necessary.

KSLBC2 is for applications where its 3" height is preferred over the standard 4".

Casters are not intended for use with stacked bins or with machine stands.



Bulletin Number: PS - 1 - 2001
Bulletin Date: January 2001

SERVICE BULLETIN

Subject: AutoSentry and RO Water

RO (Reverse Osmosis) purified water is available in several grades of purity. The typical grade of RO water used as the water supply for an AutoSentry controlled Flaker* works fine. However, ultra-pure water that does not conduct electricity will interfere with the ice machine's operation. If the water is so pure (as water becomes more pure its ability to conduct electricity is reduced) that electricity cannot be conducted, the conductivity probe in the reservoir cannot sense the presence of water and will not allow the machine to start.

The conductivity level for the water supply to these models must be no less than 35 micro/Siemens / cm.

If you require any additional information, contact Scotsman Technical Service.

* Including models NDE554, NDE654, NDE754, FDE474, NME654, NME954, NME1254, NME1854, NME2504, FME804, FME1204, FME1504, FME2404, or FME3004.



Bulletin Number: PS - 2 - 2001
Bulletin Date: February 2001

SERVICE BULLETIN

Subject: SCE275 model change.

The SCE275 has had a model series revision from "A" to "D", for example, the SCE275A-1A is now SCE275A-1D.

The change to the "D" series is due to a change to a new compressor starting device (a PTCR), and a related controller change. Production began with date code 08R.

PTCR and Controller Change

The PTCR (Positive Temperature Coefficient Resistor) replaces the start capacitor and potential relay in the D series SCE275. The part number for the PTCR is **18-8835-01**.

A new controller has been developed to work with the PTCR. That new controller's part number is **A37703-024**.

Controller Applications:

The replacement controller for the A or D series (with PTCR) is the A37703-024, this part will work in any SCE275, and is the only **replacement controller for the SCE275, replacing the 12-2543-24**.

The 12-2543-24 controller will no longer be produced, however existing parts may still be used on any SCE275, A or D series.

Compressors

Replacement compressors for the SCE275 now include a PTCR along with the prior starting components. Note: The PTCR cannot be used on the A series machines, the original design start capacitor and relay must continue to be used.

The service manual has also changed, the new manual part number is 17-2805-01.

SERVICE BULLETIN

Subject: ERC Remote Condenser Service Parts

The following is a list of the main service parts for the ERC series of remote condensers. Complete parts lists are available in the cuber or flaker they are designed to be connected to.

Model	Fan Motor	Fan Blade	Headmaster (if internal)
ERC101	18-8796-01	18-8800-01	In ice machine
ERC151	18-8796-32	18-8800-01	In ice machine
ERC201	18-8796-32	18-8800-01	In ice machine
ERC301	18-8797-32	18-8800-01	In ice machine
ERC302	18-8796-32	18-8800-01	In ice machine
ERC401	18-8796-32	18-8800-01	In ice machine
ERC402	18-8796-32	18-8800-01	In ice machine
ERC111	12-2651-02	18-8816-01	16-1044-01
ERC211	12-2651-02	18-8816-01	16-1044-01
ERC311	12-2651-01	18-8816-01	16-1044-01
ERC411	12-2651-01	18-8816-01	16-1025-01
ERC611	12-2717-01	18-8820-01	16-1044-01

SERVICE BULLETIN

Subject: 24v Transformers

The part numbers for a number of 24 volt transformers are changing. The new transformers differ slightly in that their terminal connections are on the side, not the top.

Old Part Number	Used on	Primary Voltage and Hz	New Part Number
A37231-001	CME256, 506	120/60	A37231-001 (kit with new transformer in it)
12-2617-21	CME656, 806, 1056, 1356, 1656, 2006	208/60 or 240/60	A37217-001
12-2643-01	CME306, 456, CD200, HD356, SCE275-1	120/60	12-2836-01
12-2639-02	CME256-6D, 306-6, 456-6, 506-6, 656-6, 806-6, 1356-6, 1656-6	230/50	12-2639-02
12-2642-02	CME1056R-6	240/50	12-2837-02
12-2643-02	SCE275-6	240/50	12-2836-02
12-2642-01	CME456R	115/60	12-2837-01

The new transformers differ from the old in two other ways:

1. The primary voltage for 208 - 230 volt units is now selectable. There are three terminal posts on the transformer primary: COM, 208 and 240. The 208-230 volt units will ship with the power supply on the COM and 208 posts. If the ice machine is installed in a high voltage area, (supply voltage greater than 229) the power supply should be changed to COM and 240.
2. The higher primary voltage (208 or greater) transformers have an internal circuit breaker that can be reset in case of overload.



Bulletin Number: PS - 5 - 2001

Bulletin Date: March 2001

SERVICE BULLETIN

Subject: CME2006 Panel Insulation Kit

A product improvement has been developed for the CME2006. The purpose of the improvement is to reduce the volume of sound emitted from the ice machine during the harvest cycle. The improvement is effective with all CME2006s shipped after March 1.

A field kit has also been developed to allow the improvement to be placed on prior units. The kit number is **SRKLG**. It consists of foam inserts that are designed to be placed onto the inside of the left half of the top panel, the inside of the left side panel and the inside of the left half of the front panel.

SERVICE BULLETIN

Subject: IS160 and RS160 when used with CME306 or CME456

Placement of a CME306 or CME456 onto a IS or RS160 requires the use of the KADUN2 adapter. In most cases this is the only additional kit that is needed.

However, in some installations ice falls too far forward and contacts the manual fill door. To prevent that from occurring, an ice retainer has been developed. Its part number is: **A37897-021**.

It must be attached to the KADUN2 by drilling two holes and securing it to the adapter with the supplied sheet metal screws.

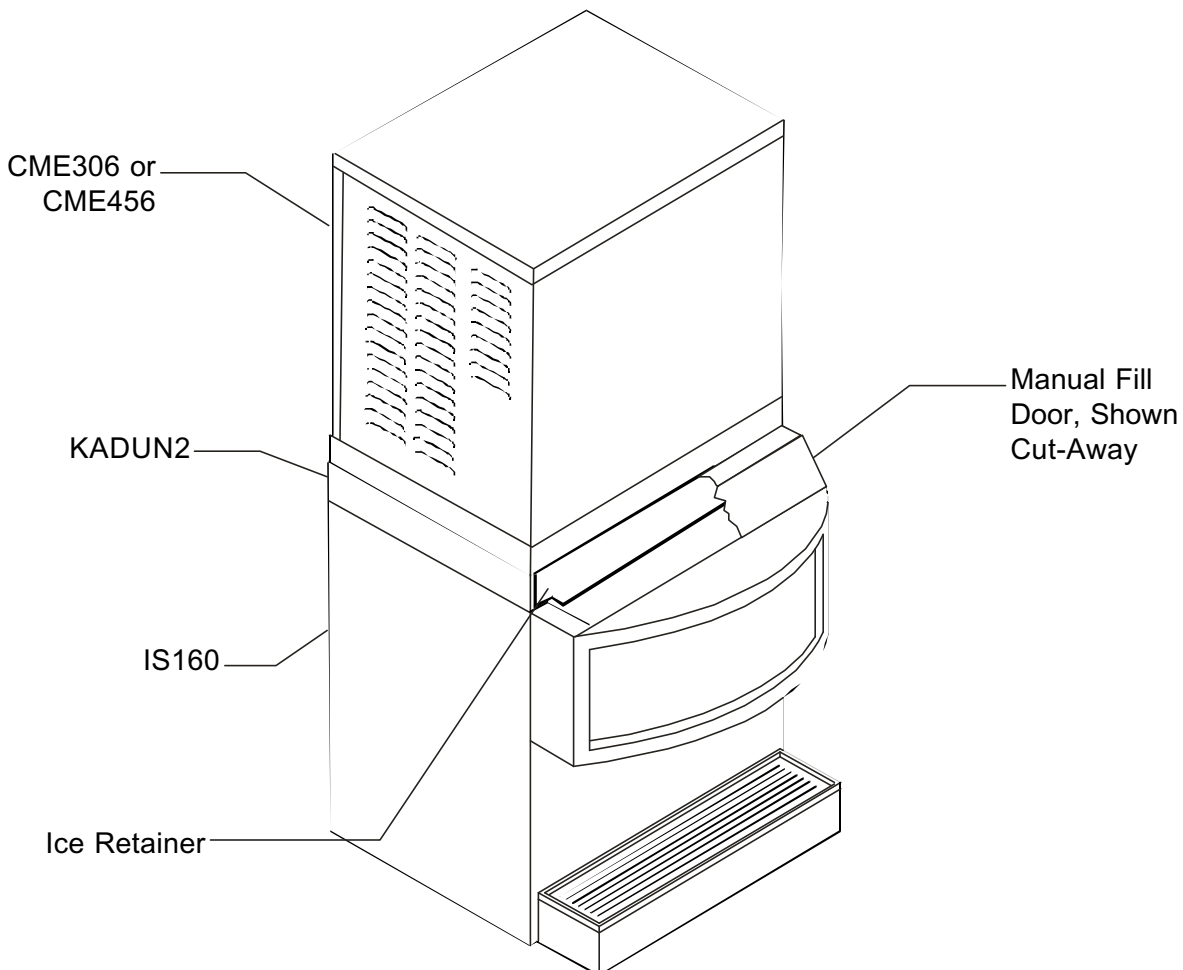

SERVICE BULLETIN

Subject: Stacking kit for CME1356, CME1656 and CME2006

The stacking kit for the CME1356, CME1656 and CME2006 has been changed. The new kit's number is: **KSCME6-LG-B**.

This kit includes the gaskets, brackets, shields, hardware and the controller harness required to stack any combination of these three models. The new kit is simpler, easier to install and more tolerant of installation variables. The prior system included an upper unit drain that is no longer used.

One key difference is the shields used to guide the ice through the lower unit. The shields for the new kit hang from hooks and are aligned by gravity. They also have tabs to limit their outward movement. The tabs insert into the ice outlet port of the bottom unit, as shown below.

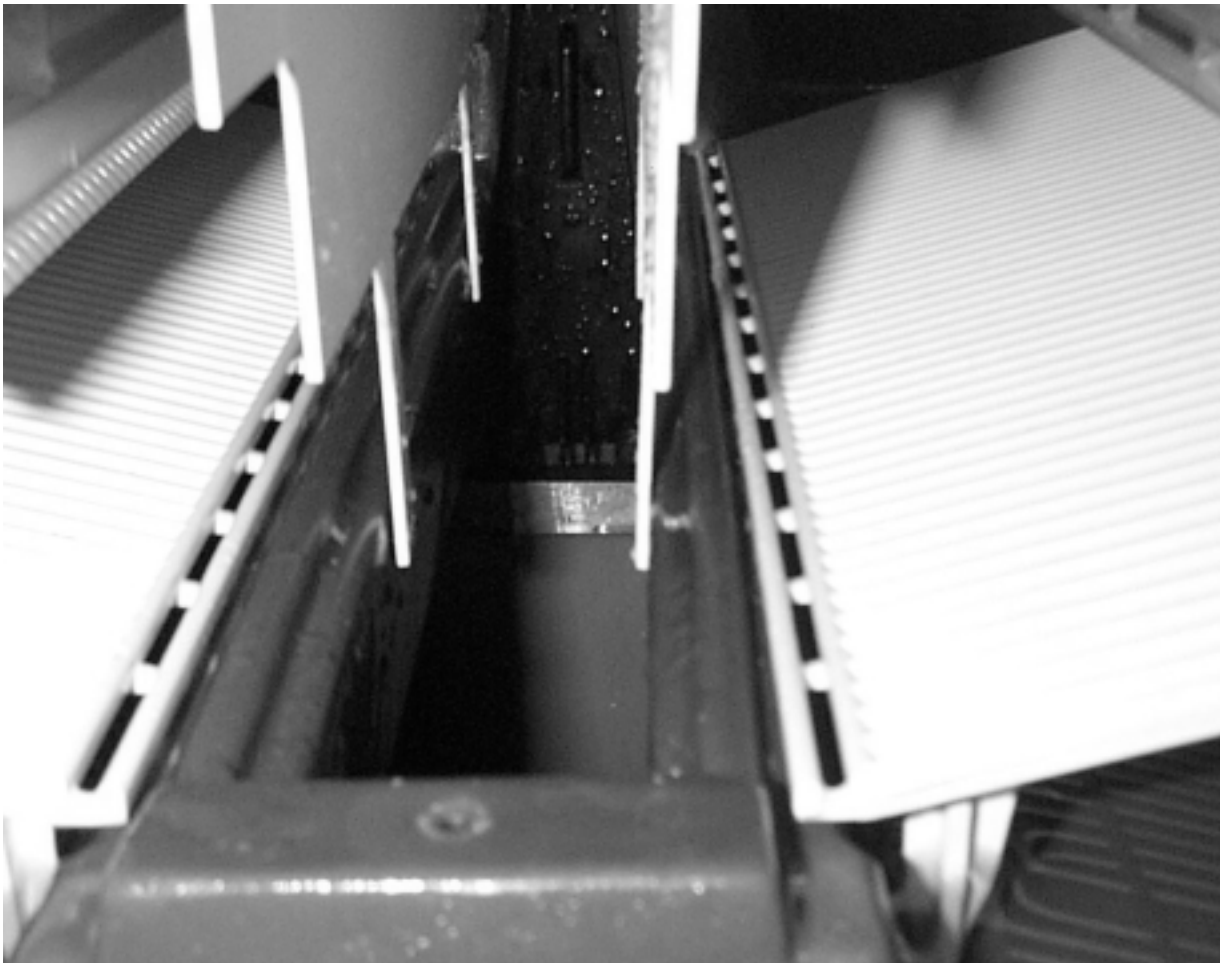

SERVICE BULLETIN

Subject: IS160, IS220, RS160 and RS220 Change - supercedes PS-6-2001 and PS-11-96.

The ice and ice and beverage dispensers now being produced have changed.

The changes include:

- New graphics - no part number change
- New, shorter radius, sweep arm for the 220s. The part number is **02-3916-01** and fits all 220s.
- New front cover or lid for use when an ice machine is stacked on the unit. The part numbers for the front covers are: RS/IS160: **02-3915-01**, RS/IS220: **02-3915-02**

The changes eliminate the need for the KADCM2 and KADUN2 adapter kits. Because the adapter kits are no longer needed, installations of these dispensers with ice machines on them will be lower in cost, ice level, and overall height than the prior models.

The changes began with the following units: IS160 BF 419279-01R; IS160 LF 419326-01R; IS220 BF 419346-01R; IS220 LF 419404-01R; RS160 BF 419421-01R; RS160 LF 419461-01R; RS220 BF 419496-01R; RS220 LF 419538-01R

The dispensers now ship with the regular hopper cover or lid that they always had; additionally a separate, short front cover will also be shipped in each unit, packed with the sink assembly. This cover will fill the space between the front edge of the ice machine and the front of the dispenser hopper.

When installing an ice machine directly onto the dispenser, foam gasket tape (such as Scotsman Part Number 19-0503-04) is recommended to be used as a sealing surface between the ice machine and the dispenser's top edge. The 160s will need about 6 feet of tape, and the 220s will need about 7 feet.

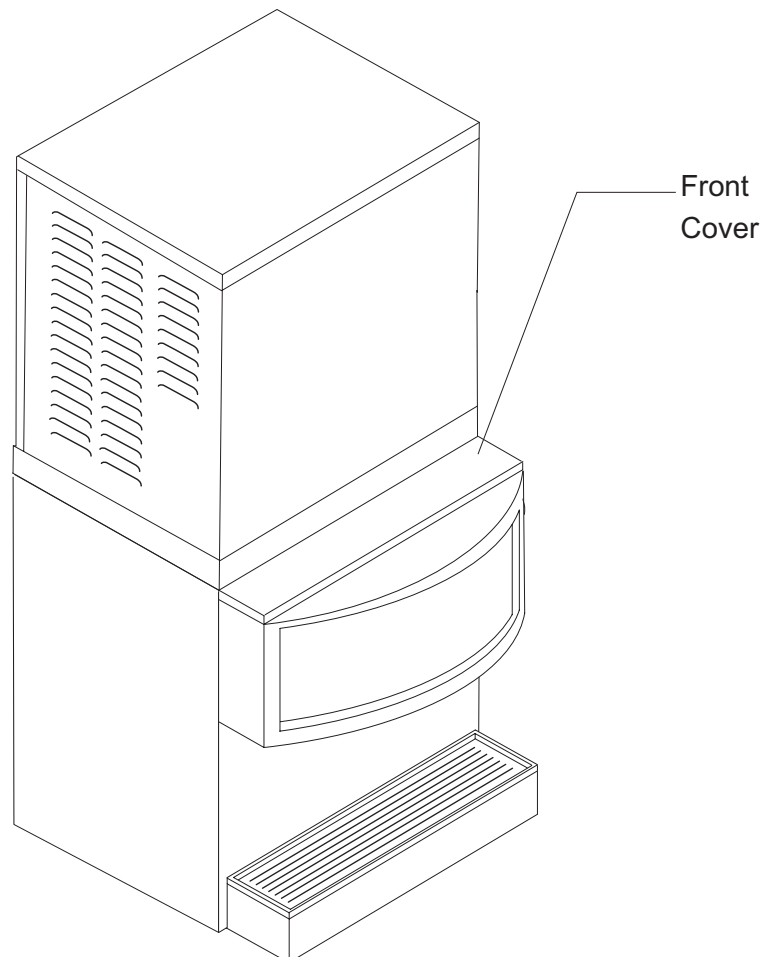

SERVICE BULLETIN

Subject: CSW45 Update

Clean Light Diagnostics:

The current control board used on the CSW45 is labeled with number 6100499 (this is not the service part number). Use of this control board began in October 2000, and it has been used as a service part since that time.

If the Clean light is flashing on units with this control there are two possible causes:

1. The bin thermistor is not sensed. The Clean light will flash on and off every second.
2. Exceeded maximum harvest time. The Clean light flashes on and off every ½ second.

The typical causes for the long harvest cycle include low charge, hot gas valve problem, big slab of ice stuck on the evaporator.

Other Diagnostics:

Place the CSW45 into the clean mode. At the start of the clean mode the 6100499 board will check the bin and evaporator thermistors.

- If the Clean light blinks 2 times the bin thermistor is disconnected or failed.
- If the Clean light blinks 5 times the evaporator thermistor is disconnected or failed.

If there is no failure light the reason for the long harvest is not the control system, but could be anything that interferes with the ice slab releasing to the grid.

Ice Guides:

The CSW45 had a design change approximately August 2000 to add ice guides (part number 02208566) to guide the ice slab onto the grid. When placing guides onto a prior model, be sure to bend the stainless steel mounting tabs (part of the grid frame) out slightly, about 3/16".

Other Issues:

- On pump models, (CSW45PA), the drain pump will shut the machine off if the water in the pump's reservoir exceeds a maximum height. At start up, the CSW45 opens the water valve to fill the ice machine reservoir. If the outlet hose of the drain pump is restricted, the pump cannot force the water out fast enough and the pump's reservoir will overflow, causing the pump to shut off the inlet water valve and any other load, such as the bin light. The cure for this is to be certain that the drain hose is not restricted.
- Water inlet tube mis-placement can cause it to freeze shut if next to the evaporator. Check and re-route.
- Evaporator thermistor must make good contact with the suction line or the slab will be too thick.

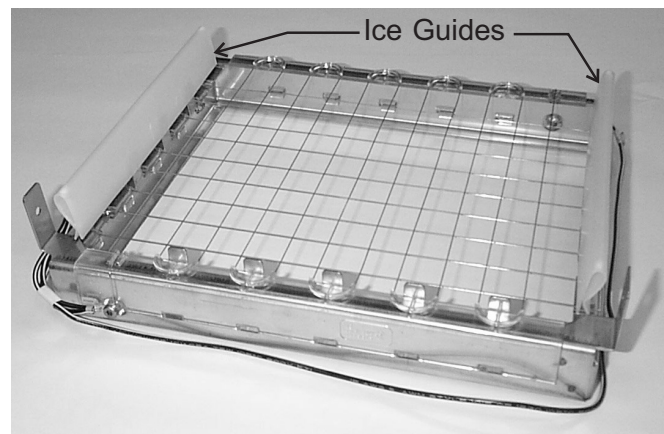

CSW45 Grid, Shown with Ice Guides



Bulletin Number: PS - 10 - 2001
Bulletin Date: October 2001

SERVICE BULLETIN

SUBJECT: MDT Changes

MDT3 and MDT4: The location of the touch free sensor has been moved closer to the ice dispensing spout. This was done by moving the mounting holes in the splash panel up towards the spout. The part number of the splash panel (02-3878-01) that locates the sensor has not changed, but the hole location has. All MDT3s and MDT4s shipped since August 17, 2001 include this change.

MDT6: A new spout and water tube have been designed and are now part of all MDT6s. They move the dispensing area closer to the splash panel.

- The new ice chute part number is **02-3909-01**
- The new water tube part number is **A34601-002**
- The new ice chute/solenoid cover is **A35321-003**

Mounting bracket A37883-001 has been modified to accept the new spouts. All MDT6s shipped since September 1, 2001 have this change.



Bulletin Number: PS - 11 - 2001
Bulletin Date: September 2001

SERVICE BULLETIN

Subject: CSW45 Model and Compressor Change

The CSW45's model numbers are now CSW45A-1B and CSW45PA-1B. The B series machines have a different compressor from the original A series.

The new compressor part numbers are:

Compressor: **02208490** (complete with relay, overload and terminal cover)

Relay: **02217224**

Overload: **02217223**

The A and B series compressors are NOT interchangeable.

SERVICE BULLETIN

SUBJECT: CS60 and CSE60 Spray Platform

The spray platform, 0793129-02, has been changed. Fasteners have been added to retain the nozzle plates to the platforms. The prior nozzles and gaskets will not fit the new platforms and are no longer available. **New** nozzles and gaskets are now available as a **set of 3** (part number 0660519-01) and include new fasteners so they can fit either platform.

The starting supply date for spray platforms with the new nozzles is January 2002.

The starting serial number of the CSE60s with the new platforms is 419836-06R.

Part numbers have not changed.





Bulletin Number: PS - 13 - 2001
Bulletin Date: December 2001

SERVICE BULLETIN

SUBJECT: Thermostatic Expansion Valve Changes

SCE170 B Series: The replacement TXV for this series machine has been changed. Although the service kit part number remains 16-0868-22, the TXV supplied in the kit is now part number 16-0868-03.

When installing a 16-0868-03 TXV on a **B series SCE170 that had the prior valve**, relocate the TXV bulb from its vertical suction line location to the horizontal suction line position, just to the right (when viewed from the back) of the cube size control bulb.

Production of SCE170s with this valve began in early November, 2001, and they have the TXV bulb next to the cube size control bulb, so they do not require bulb relocation when replacing the TXV.

The A series valve does not change.

AFE400: The replacement TXV for the AFE400 has been changed from 16-0996-01 to **16-1091-21**. These valves are completely interchangeable. Production of AFE400s with the new valve began in early December, 2001.



Bulletin Number: PS - 1 - 2002
Bulletin Date: January 2002

SERVICE BULLETIN

SUBJECT: New Replacement Cuber Controller

Products Affected: All CM³, including CME256, CME306, CME456, CME506, CME656, CME806, CME1056, CME1356, CME1656, CME2006 and SCE275

What Has Changed: Individual replacement controllers for the above machines have been consolidated into a single service part.

What To Do: Use the prior controllers until they are gone. Stock a single part number controller in the quantity needed for future use.

Prior Part Number - Model Used On	New Part Number - Used on All
A37703-021 – CME256, 506, 656, 806	12-2838-21
A37703-023 – CME1356, 1656	
A37703-024 – SCE275	
A37703-025 – CME2006	
A37703-026 – CME1056	
12-2727-22 – CME456	
12-2727-23 – CME306	

The new controller contains all the individual programs the individual controllers had. The correct program must be selected by the installing technician by looking up the model number in a table (like the one below) and turning a rotary switch to the correct setting.

For Model	Set Switch To
CME256, CME506, CME656	0
CME806	1
CME1056A, CME1056R	2
CME1056W	3
CME1356, CME1656	4
CME2006	5
CME306	6
CME456	7
SCE275	8

The new controller, enclosed in a blue housing, has two other significant features:

1. It displays a code that identifies which program it is set for.
2. It can display the last two diagnostic codes (if any) it has encountered.

Program Code ID:

The code is displayed at power up, after all the lights have flashed ON. The code is the green light display, the two red diagnostic lights blink while this code is shown. It goes off after 20 seconds.

Green Lights Displayed	Controller is Programed For Model
None	CME256, CME506, CME656
Clean	CME806
Harvest	CME1056A, CME1056R
Clean and Harvest	CME1056W
Freeze	CME1356, CME1656
Freeze and Clean	CME2006
Freeze and Harvest	CME306
Freeze, Harvest and Clean	CME456
Bin Full	SCE275

Diagnostic Code Recall Process:

1. Push and hold the Off button to shut the machine off.
2. Push and hold the Off button until the green lights flash on.
3. Push and release the Harvest button to display the last code.
4. Push and release the Harvest button again to display the second-to-last code (the Bin Full light will also come on to signify that its the second to last code).
5. Push and hold the Off button to return to the regular mode.
6. Push and release Freeze to restart.

Other Differences:

Bin full light temporarily ON after program code at power up

Bin full light does not blink when a hand or something is stationary between sensors – moving the blockage will cause it to blink

If ice sensors are blocked for 5 seconds the Bin Full light will go directly from Off to On; the prior control showed 20 seconds of blinking before registering a bin full

On models that use a thermostat, the bin full light switches on after 5 seconds of the thermostat being closed and goes off when the thermostat is open – unless the compressor has been in operation, then it stays on for 4 minutes after compressor shut off (like the prior control).

The Harvest light is On during Harvest during a restart after a power interruption. The prior control blinked the Freeze light during all parts of the power interruption restart.

Water Level Sensor test has new values for use with this controller - see PS-2-2002.

The ice sensor go/no-go test has also been changed to work with this controller - see PS-2-2002.

SERVICE BULLETIN

Subject: Diagnostic Changes for Blue CM³ Controllers

Controllers with blue housings work the same as the prior black controllers. However, in two areas they are different: Water sensor diagnostics and ice sensor diagnostics. This bulletin will detail how to diagnose these two components.

Water Level Sensor - for use with Black or Blue Controllers

Tools Needed: Digital voltmeter that can read DC

Goal: To determine if the water level sensor is capable of normal operation.

Note: Ambient light can affect this test. Shade the sensor if needed.

1. Unplug water sensor harness from controller (connection #2).
2. Confirm that the power to the machine is ON and that there is at least one light on the board that is glowing. If not, check the transformer.
3. Set the voltmeter to DC and use a scale low enough to measure less than 40 Volts.
4. Measure the voltage between the top and the bottom pins on the controller at connection #2 (the bottom is ground or negative).

	Yellow (bottom) - Black Housing Controller	Yellow (bottom) - Blue Housing Controller
Blue - harness unplugged	24 to 30 VDC	.5 to 2 VDC

If it is much less than that, there is something wrong with either the power supply to the controller or the controller itself. If the voltage measures correctly proceed to the next step.

5. Reconnect the harness. Be SURE it is on properly and has a good connection. To confirm, unplug the harness from the water sensor and redo step #4 at the end of the harness. Then plug the harness back onto the sensor.

Harness Connected Voltage (DC)

6. At the controller, measure the voltage between the top and bottom pins on connection #2. This should be between the ranges in the table below. If it outside this range there is a problem in the sensor and it should be changed out. If it is within this range, proceed to the next step.

	Yellow (bottom) - Black Housing Controllers	Yellow (bottom) - Blue Housing Controllers
Blue (top)	2 to 3.5 VDC	.4 to 2.0 VDC

7. Place negative voltmeter probe on the bottom terminal (yellow wire). Place the other on the one just above it (terminate freeze sender - white wire). Move the float stem/stick up and down and note the voltage changes. There should be a significant change between when it is blocked to when it is not blocked. If there is **NO change**, the sensor may be dirty or has failed. Remove the dust cover from the sensor to clean it.

Note: The sensor must be properly reassembled. When looking at the terminals of the sensor, they must be in the lower right corner. If they are in the upper left remove the sensor's dust cover and reverse the board. Later models have an UP arrow on the right side of the circuit board.

	Yellow (bottom) Black Housing Controllers	Yellow (bottom) Blue Housing Controllers
White - Blocked	5 VDC	about 5 VDC
White - Unblocked	<1 VDC	less than when blocked

8. With the voltmeter probe still on the bottom terminal (still in connection #2), place the other one on the second pin from the top (sump full sender - red wire). Move the float stick up and down, note the changes in voltage. It should react the same as in step 7.

	Yellow (bottom) Black Housing Controllers	Yellow (bottom) Blue Housing Controllers
Red - Blocked	5 VDC	about 5 VDC
Red - Unblocked	<1 VDC	less than when blocked

9. If all voltages check out, there is nothing wrong with the sensor or the voltage it receives from the controller.

Ice Sensors (also called bin eyes)

Diagnostics assume that the control system is working but may not be able to sense cubes. Its purpose is to determine which component may be at fault - the controller or the ice sensors.

Black Controllers

Unplug thermostat (if used) and check bin full light, if off, place something between the electric eyes. The bin full light should begin glow steadily after 20 seconds of continuous blockage. If not, check operation of electric eyes by unplugging #4 and jumping out the two pins on the controller (touch the tool to the cabinet to discharge static electricity before contacting the controller). If the bin full light blinks, replace the bin controls. If it does not blink, replace the controller.

Blue Controllers

Unplug thermostat (if used) and check bin full light, if off place an object between the ice sensors, after 5 seconds the Bin Full light will be glowing steadily, if not check operation of sensors by unplugging #4. Bin Full light will go on after 5 seconds, If not, replace controller. If the light does go on, replace ice sensor set.



Bulletin Number: PS - 3 - 2002
Bulletin Date: February 2002

SERVICE BULLETIN

Subject: CME1356 and CME1656 E Series

The left side panel on the above air cooled models has been changed. It is now louvered and the air cooled E series takes air in from the front AND the left side. Warm air is discharged out the back as before. Both intakes have air filters (part number 02-3485-01) under them.

A baffle has also been added, similar to the ones used on the CME1056A, CME306A and CME456A. It ships attached to the back panel and is intended to be installed at the left edge of the condenser to reduce air recirculation when the machine is installed in a corner. The baffle's part number is A38011-001.

The new louvered panel is not interchangeable with prior CME1356s or CME1656s, and cannot be placed on water cooled or remote cooled units.

E Series Left Side Louvered Panel Part Number.....A38025-001

Although the prior left side panel must be used as a replacement on the A - D series, there is a retrofit kit.

Retrofit Kit: A kit is available to add gaskets, a baffle and a stainless steel louvered left side panel with filter to A - D series air cooled CME1356 and CME1656 machines. The kit number is: **A37983-001**. Note: The left side panel in the kit is different from the left side panel used on the E series units, and they are not interchangeable.

Additional Change:

Production of the CME1356 and CME1656 with the blue controller begins with the E series.

Beginning with February 2002 production, the CME2006 will also start using the blue controller. The new controller's use will be phased in by model throughout 2002.

SERVICE BULLETIN

Subject: New Ice Sensors in CME1356, CME1656 and CME2006. New Ice Sensors, new Water Level Sensors and new Controllers in CME306 and CME456.

Ice Sensors: Scotsman has begun production of ice machines equipped with a new style of ice sensor. The new sensor is interchangeable with the prior sensors, which are still in use on other Scotsman modular cubers.

Controllers: Scotsman has also added the new blue controller (see PS-3-2002) to models CME306 and CME456.

Water Level Sensor: A new water level sensor is also being used on CME306 and CME456.

Service parts for the ice sensors and water level sensor have not changed.

Ice machines built prior to this change are not affected.

The new sensors' use will be phased in by model throughout 2002.

Additional information is on the back of this bulletin.

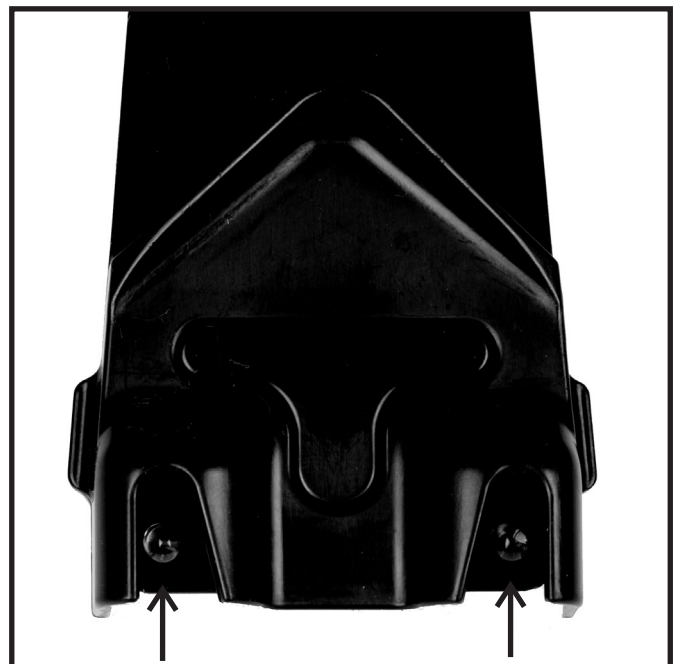

Photo-Eyes in New Ice Sensor

Sensor Holder



Push to Release Photo-Eye Module

The new ice sensor's have a photo-eye module that can be separated from the holder.

Once separated, the lenses of the photo-eyes can easily be cleaned with a soft cloth or cotton swab. Ice machine cleaner may be used if needed.

Like the other style of sensor, the photo-eye part can be placed in the reservoir when the ice machine is being cleaned with ice machine cleaner.

When re-assembling, be sure that the wire is not sticking out past the edges of the sensor holder.



Photo-Eye Module Separated from Holder



Route Wire Under Clip, Push Module Into Place



Bulletin Number: PS - 5 - 2002
Bulletin Date: March 2002

SERVICE BULLETIN

Subject: CME256, CME506, CME656 CME806 and CME1056 E Series

The non-louvered side panels on the **remote** and **water cooled** models have been changed. They are not interchangeable with prior series machines, and cannot be placed on air cooled units.

New Part Numbers for E series remote or water cooled:

Left Side PanelA38127-021
Right Side PanelA38126-021

The prior panels must be used on A - D series.

CME506E Series - Additional Change

The refrigeration system of all CME506s, including air cooled, water cooled and remote air cooled has been changed.

The new system uses two internally equalized TXVs with check valves in place of a single externally equalized TXV with distributor. A new air cooled condenser is also being used, as is a new refrigerant charge amount.

New Part Numbers:

CME506 E series TXV:16-1009-22
CME506 E series check valve:16-1071-01
CME506 E series air cooled condenser:18-8866-02

New Charge:

CME506AS-1E23 ounces, R-404A
CME506WS-1E14 ounces, R-404A
CME506RS-1Eno change, still 224 ounces

The prior charge amount, TXV and air cooled condenser must be used as replacements on all prior CME506s (A through D series).

CME1056 E Series - Additional Change

Production of the CME1056 with the new blue controller begins with the E series. The new controller's use will be phased in by model throughout 2002.

SERVICE BULLETIN

Subject: Modular Cuber Ice Sensor Change

The service replacement ice sensor for the CM³ modular cubers has changed.

Prior part numbers	Used on	New Service Part Number
02-3409-21	CME256, 506, 656, 806 and 1056	11-0540-21
11-0536-21	CME306 and 456	
A37728-021	CME1356, 1656, 1856, 2006	

This change creates a common service ice sensor for all CM³ modular cubers.



New Ice Sensor, Emitter Shown

The SCE275 ice sensor set has not changed.

Also changing is the water level sensor, part number 02-3707-21. Its new part number is **11-0539-21**.



Bulletin Number: PS - 7 - 2002

Bulletin Date: April 2002

SERVICE BULLETIN

Subject: SCE275 Control System Change: New Controller, new Ice Sensors and new Water Level Sensor

Controllers: Beginning in early April, SCE275s began being manufactured with the blue controller (see PS-3-2002).

Ice Sensors: Also beginning in early April, SCE275 ice sensors changed manufacturing part numbers. The new sensor is identical in appearance to and interchangeable with the prior sensors. There is no change to the service part number.

Water Level Sensor: A new water level sensor is also being used on the SCE275.

Ice machines built prior to this change are not affected.

The service part number for the CM³ water level sensor is being changed. The new replacement part number is **11-0539-21**.

The sensors are completely interchangeable. Either part number 02-3707-21 or 11-0539-21 can be used on any CM³ model.

SERVICE BULLETIN

Subject: New Ice Storage Bin model BH360S

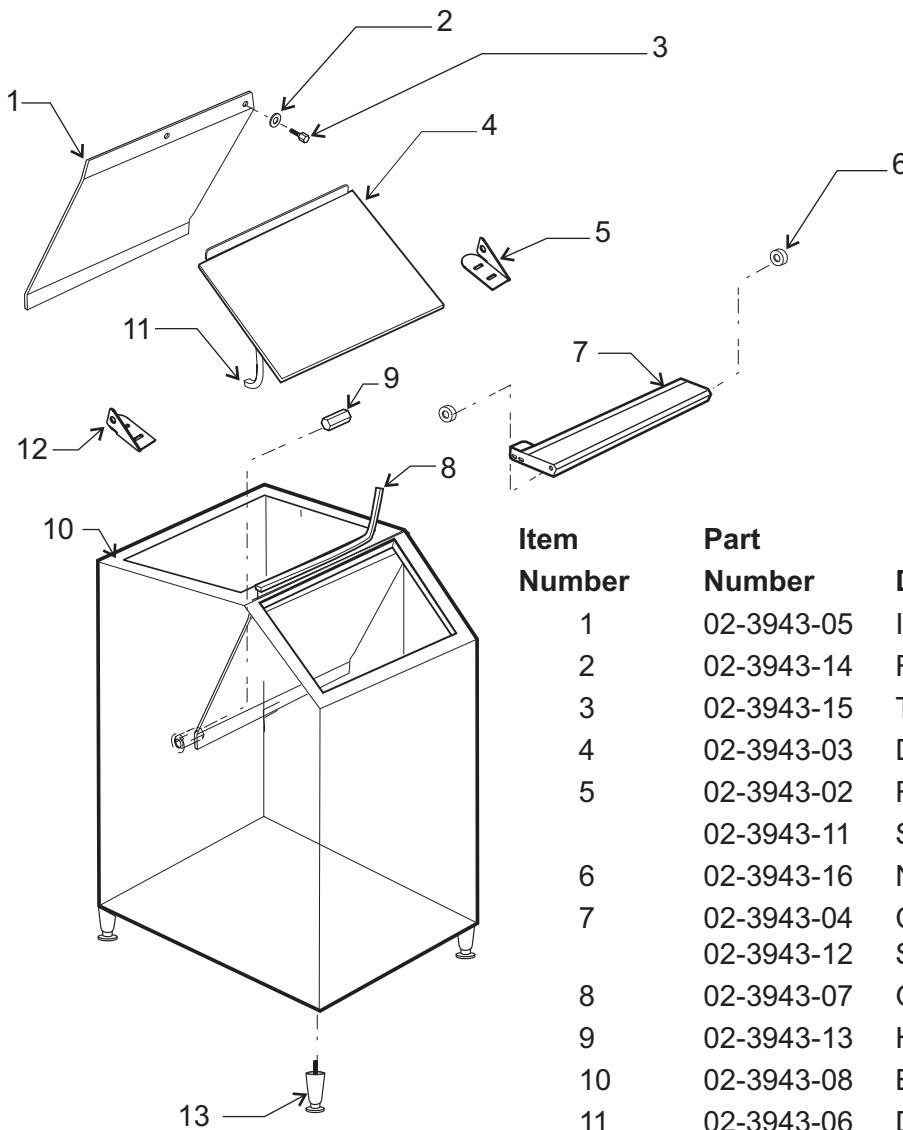

Item Number	Part Number	Description
1	02-3943-05	Ice deflector
2	02-3943-14	Rubber washer
3	02-3943-15	Thumbscrew
4	02-3943-03	Door w/gasket, w/out hinges
5	02-3943-02	Right hinge
	02-3943-11	Screw, hinge to door
6	02-3943-16	Nylon bearing
7	02-3943-04	Canopy
	02-3943-12	Screw, canopy to bin
8	02-3943-07	Gasket (per foot)
9	02-3943-13	Hex stand off
10	02-3943-08	Bin gasket tape (per foot)
11	02-3943-06	Door gasket
12	02-3943-01	Left hinge
	02-3943-11	Screw, hinge to door
13	02-3943-10	Set of 4 legs
14	02-3943-09	Connecting strap, IM to bin

Note: Leg Threads are ½ - 13. The legs for this bin will not interchange with any other Scotsman leg or caster.

SERVICE BULLETIN

Subject: HD356 Drain Pan, Coin Op and Cam changes

The size of the drain line from the drain pan to the cabinet drain of the HD356 has been enlarged for improved draining.

This change required a change to the drain pan. The drain pan kit part number is **A38021-001**, replacing A34694-001. The kit includes a pan, new tubing and a new adapter. All HD356s built after date code -02R have this change.

The coin mechanism model of the HD356, HD356NS-1C, has been changed. An internal baffle has been added to restrict the flow of ice out of the hopper when it is filled to capacity with ice. The baffle's part number is A37933-001, and its two brackets are A37898-001 and A37898-002.

The change began in May 2002.

Another change to the HD356 is to the cams. This change began with sn 425102-01R.

All HD356s now use the same cams. The new cams have three stop positions, so the bin rotor will only turn 1/3 revolution per vend cycle.

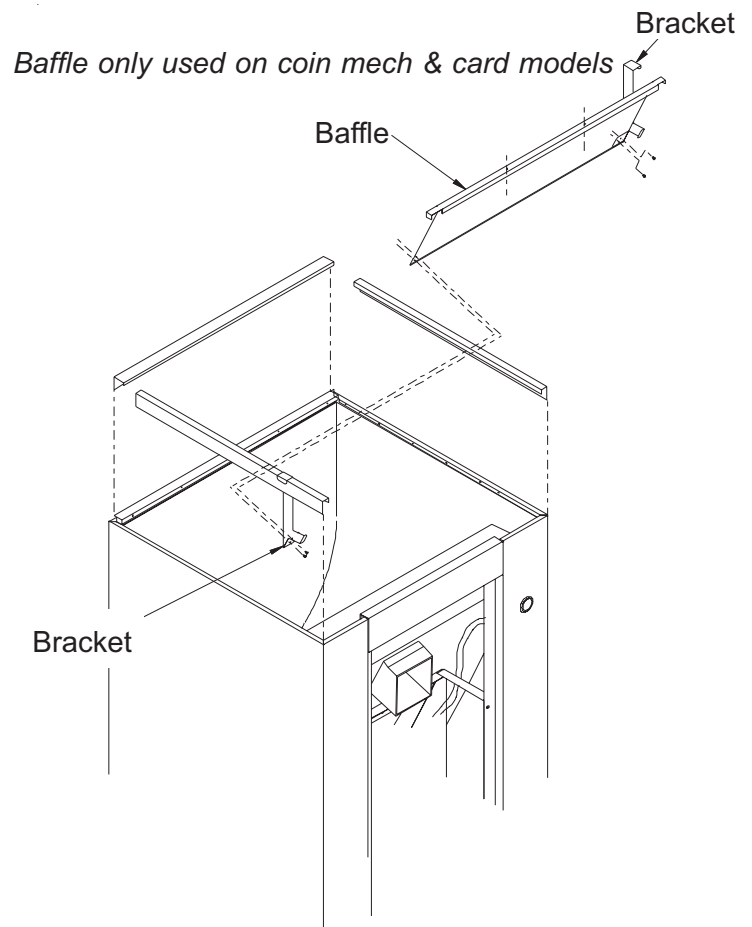
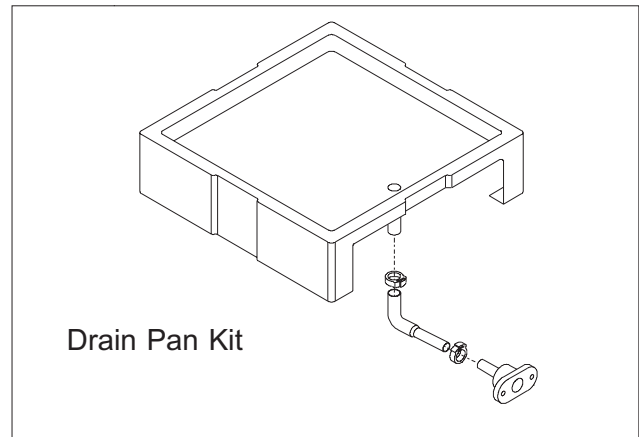

CAMS	HD356 old	HD356 new
Top - button	A37308-001	A37851-001
Top - coin	A34705-001	A37851-001
Bottom (closest to the gear case)	A29734-001	A37852-001



Bulletin Number: PS - 10 - 2002
Bulletin Date: June 2002

SERVICE BULLETIN

Subject: MDT3, MDT4 Updates

The MDT3 and the MDT4 have been changed.

Packaging. The carton and skid for these two models have been made wider to improve their shipping stability. The prior carton width was 16", the new width is 23.25". This change began 5/10/02.

Spout: A clear plastic spout, part number **02-3944-01**, replaces the 02-1804-00 spout. The new spout is a direct replacement for the prior spout and attaches using the same screws. The new spout is 2" longer than the old one and tapers to a 2" ID outlet, providing a more accurate path for ice during dispensing. This change began 5/10/02.

Bin Bottom: Bin bottom **A38272-001** replaces A34767-001. The new bin bottom directs the ice towards the center of the discharge chute, reducing ice build up on top of the chute.



Bulletin Number: PS - 11 - 2002

Bulletin Date: June 2002

SERVICE BULLETIN

Subject: Model Number Revisions and Water Cooled Condenser Change

Due to a change in water cooled condensers, nearly all Scotsman ice machines (including air cooled and remotes) have had a model number revision change (example, AFE400W-1A to AFE400W-1B).

A consequence of the change to new water cooled condensers is a change in refrigerant charge for most water cooled models. Air cooled and remote charges did not change. Always refer to the dataplate on the ice machine, the dataplates will have the correct charge information.

Replacement water cooled condensers must be used based on the model series of the ice machine, as the new condensers have a different tubing configuration as well as a new charge. Order the prior part for all series up to those listed below, order the new part number condensers for the new series.

The following is a list of new water cooled models (without electrical codes), charges and replacement condenser part numbers. The new condensers are all the cupro-nickel type.

Model	New Series	Ref. Charge for New Series (oz)	W C Condenser Part Number for New Series
AFE400W	B	9	18-8869-21
CME1056WS	F	28	18-8874-21
CME1356WS	F	58	18-8865-21
CME1656WS	F	58	18-8865-21
CME256WS	F	13	18-8871-21
CME306WS	B	14	18-8871-21
CME456WS	B	16	18-8871-21
CME506WS	F	13	18-8871-21
CME656WS	F	26	18-8874-21
CME806WS	F	24	18-8874-21
FME1204WS	B	22	18-8873-21
FME1504WS	B	24	18-8874-21
FME2404WS	B	22 each system	18-8873-21
FME804WS	B	19	18-8871-21
MDT5N25W	B	17	18-8871-21
MDT5N40W	B	17	18-8871-21
MDT6N90W	B	19	18-8871-21
MFE400WS	B	14	18-8871-21
NME1254WS	B	24	18-8874-21
NME1854WS	B	22 each system	18-8873-21
NME654WS	B	19	18-8871-21
NME954WS	B	22	18-8873-21
NSE654WS	B	19	18-8871-21
SCE170W	C	10	18-8869-21
SCE275W	F	12	18-8871-21

SERVICE BULLETIN

Subject: New motor shaft oil seal for 1/10 HP gear reducers

Affects: All current and prior 1/10 HP gear reducers (current replacement part number A31977-021) and includes models AFE325, AFE400, MDT3, MDT4, and MFE400.

The input shaft oil seal has been changed **from two** 02-1504-00 seals back to back to **one 02-3969-20** seal.

When replacing the input shaft seals, remove BOTH input seals and install the new seal with the U-Cup facing the oil.

Use of the new seal in finished products began on 11/19/02.



This Side Faces Motor

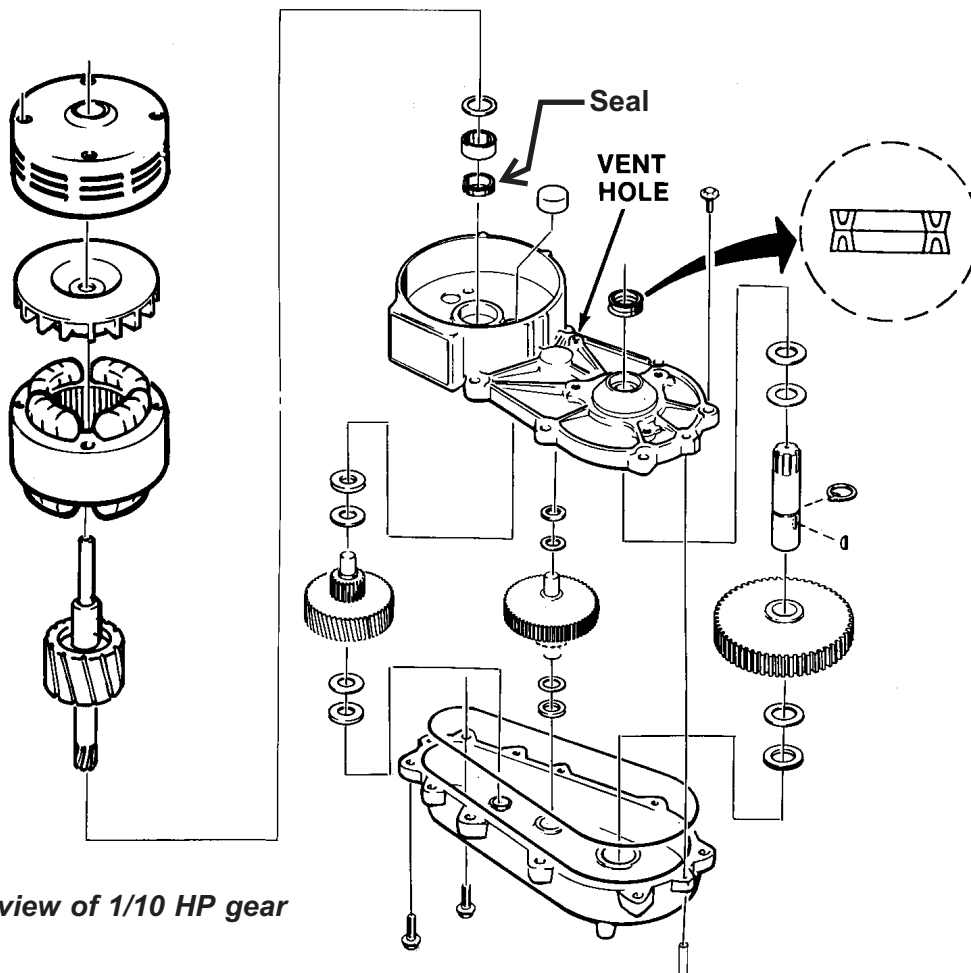

Exploded view of 1/10 HP gear reducer.



Bulletin Number: PS - 1 - 2003

Bulletin Date: February 2003

SERVICE BULLETIN

Subject: MAR1400 and MAR2000 Gear Reducers and V Belts

Gear reducer. The gear reducer for the MAR units has been changed. The new part number is M620377-04 and is completely interchangeable with the prior gear reducer. The new gear reducer's use began with units mfg. in November 2002. The old gear reducer is marked VF 30/63. The new gear reducer is marked VF/W30/63.

Drive motor mounting plate. The drive motor mounting plate has changed. The new part number is M784350-06. It is completely interchangeable with the prior mounting plate.

Drive belt. The V belt used on the MAR units with the new gear reducer is different than the one used with the prior gear reducer. The prior belt is part number M650422-22 (Z33). The drive belt to use with the new gear reducer is M650422-18 (Z35).

Drive pulleys. The MAR drive pulleys are now anodized on the outside. There is no part number change.

SERVICE BULLETIN

Subject: SCE275 Model Series Change

The SCE275 is now being manufactured as a G series. G series and higher SCE275s have their AutoIQ controller on the left side wall of the chassis, instead of the right side chassis floor. The new location provides improved protection from water and debris.

Although the controller's buttons and lights are somewhat out of sight in the new location, they can be easily seen by flashlight.

Because of the controller move, the wire harnesses have also changed.

12-2900-01 Main wire harness AC for G series 60 Hz

12-2901-01 Main wire harness WC for G series 60 Hz

12-2894-01 24 volt wire harness, AC for G series 50 Hz

12-2895-01 Pump wire harness, WC for G series 50 Hz

12-2895-01 Pump and fan wire harness, AC for G series 50 Hz

12-2892-01 24 volt wire harness, WC for G series 50 Hz

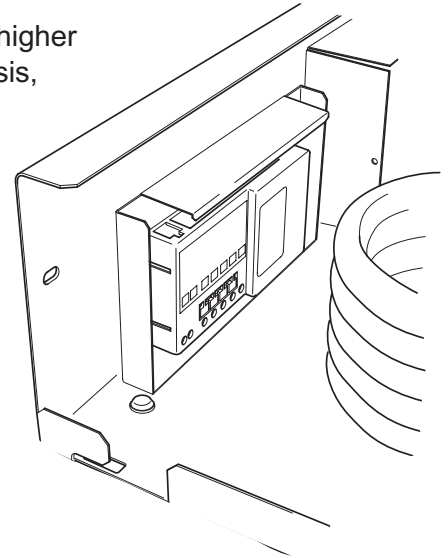

New Location for Controller



Bulletin Number: PS - 3 - 2003

Bulletin Date: July 2003

SERVICE BULLETIN

Subject: CSW45 evaporator and thermistor change to C series

The evaporator in the CSW45 has been changed. Beginning with C series units, (CSW45-1C), the suction line diameter has increased. This required a change to the thermistor that mounts to the suction line.

Replacement evaporators will now come as a kit with the matching thermistor so they will fit any CSW45.

Replacement thermistors will now come as a kit with both large and small thermistors so they will fit any CSW45.

CSW45 thermistor kit part number **A38444-021** contains both CSW45 thermistors.

CSW45 evaporator kit part number **A38445-021** contains the evaporator and the thermistor that fits it.

SERVICE BULLETIN

Subject: Service Parts for New Bin, SB480

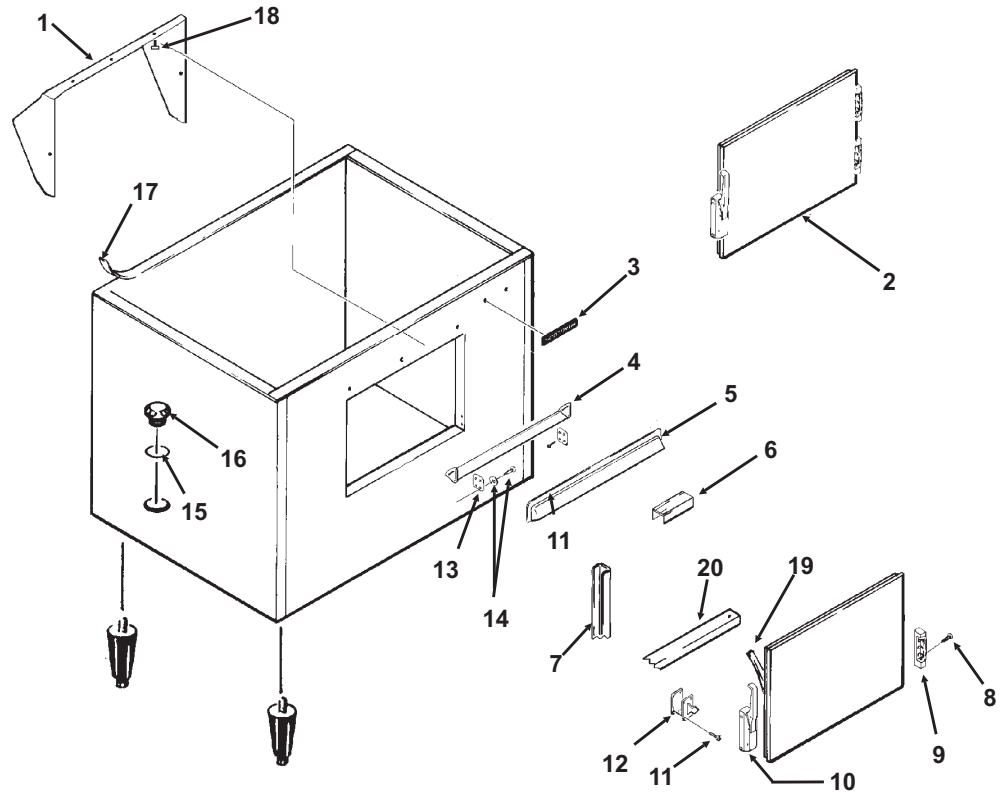

ITEM NUMBER	PART NUMBER	DESCRIPTION	ITEM NUMBER	PART NUMBER	DESCRIPTION
1	02-3991-01	Baffle	10	02-2658-01	Latch
2	02-3991-02	Complete door, SS		02-3991-12	Screw, into door
	02-3991-03	Plastic door liner	11	03-3991-13	Screw, into cabinet
3	15-0711-02	Emblem for gray	12	02-2658-02	Strike
4	02-3991-04	Spill Door	13	02-3991-15	Spill door hinge
5	02-3991-05	Awning	14	02-3991-16	Screw
6	02-3991-06	Door Trim Cap	15	13-0617-11	O-ring
7	02-3991-07	Door Trim side	16	02-2809-01	Drain top
	02-3991-17	Support, attaches to item 7	17	19-0503-04	Foam tape
8	02-3991-08	Screw, into door or cabinet	18	03-0727-01	Thumb screw
9	02-2658-03	Hinge	19	02-3991-18	Door gasket
	02-2658-04	Hinge Cover	20	02-3991-19	Door trim



Bulletin Number: PS - 5 - 2003

Bulletin Date: July 2003

SERVICE BULLETIN

Subject: CSE60 Fan Motor and Blade Change

The fan motor and blade used on the CSE60 has been changed.

Use began with sn 615621-03D to 615640-03D and 615844-04D to 615983-04D.

The new part number will be a kit that includes the fan motor, blade and motor mounting bracket so it fits any CSE60. The kit number is **0794247-18**.

The replacement fan blade will also be a kit so the service tech will always get the correct part. The kit will include two fan blades, one for the prior motor and one for the new motor. The fan blade kit number is: **18-8725-21**.

SERVICE BULLETIN

Subject: New Ice Storage Bins - BH1100, BH1300, BH1600

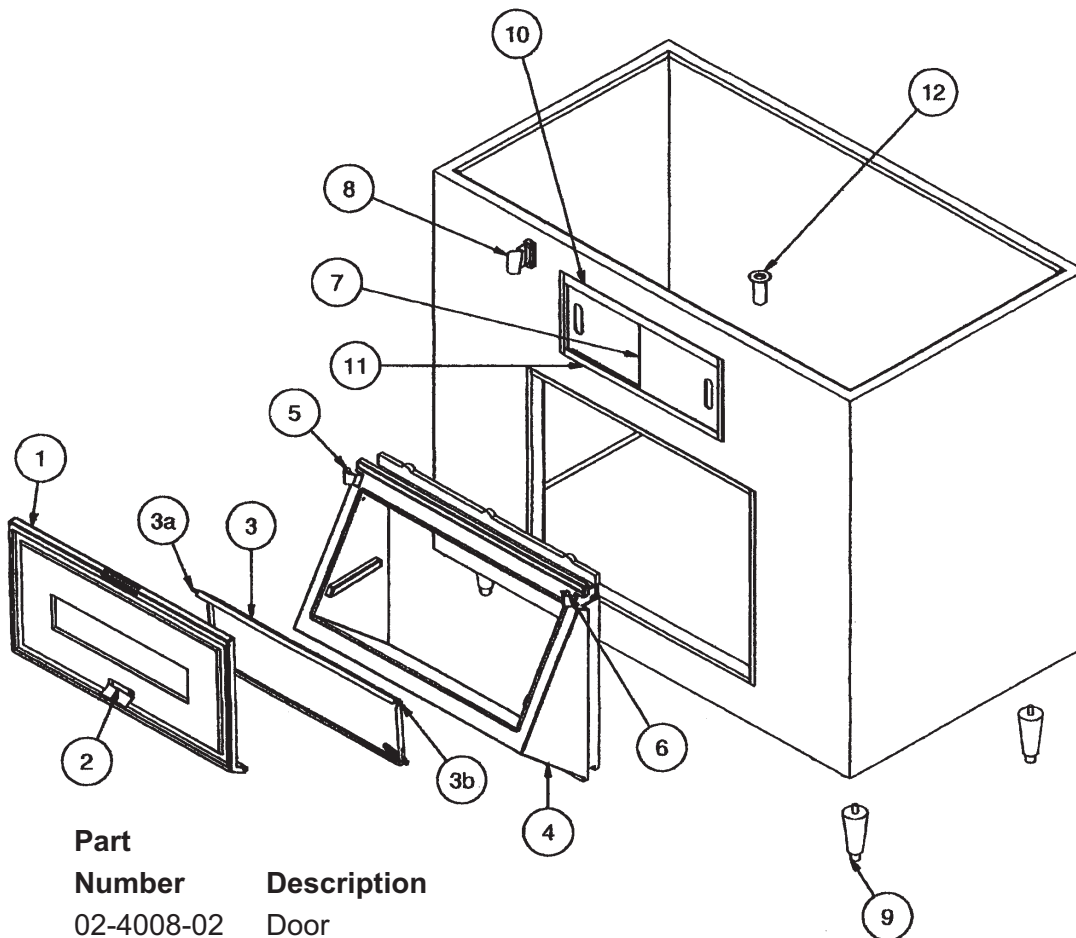

Item Number	Part Number	Description
1	02-4008-02	Door
2	02-4008-03	Baffle latch bracket
3	02-4008-04	Baffle assembly
3a	02-4008-05	LH spring loaded hinge
3b	02-4008-06	RH spring loaded hinge
4	02-4008-07	Snout
5	02-4008-08	LH door hinge
6	02-4008-09	RH door hinge
7	02-4008-10	Window
8	02-4008-11	Door latch
9	02-4008-12	Leg
10	02-4008-13	Upper window track
11	02-4008-14	Lower window track
12	02-4008-15	1" plastic drain

Not Shown

	02-4008-16	SS Top Support Frame
	02-4008-17	48" Plastic Top
	02-4008-18	60" Plastic Top
	02-4008-19	9" Filler Panel
	02-4008-20	13 1/2" Filler Panel



Bulletin Number: PS - 7 - 2003

Bulletin Date: September 2003

SERVICE BULLETIN

Subject: Air Intrusion Kits & Related Changes

30" Cabinets - CME256, CME506, CME656, CME806, CME1056

In some cases the air cooled versions of the above models will draw air into the freezing compartment from the ice storage bin, especially if the bin door is left open. Scotsman has developed a kit that reduces the flow of air from the freezing compartment. The kit number is **A38015-001** and includes a replacement evaporator cover, front panel insulation (pn 02-4006-01) and front panel gasket (pn 02-4005-01).

48" Cabinets - CME1356, CME1656, CME1856, CME2006

The 48" air cooled models were changed in early 2002 (see PS-3-2002) to improve air flow. Recently an additional change has been made to all the 48" models. That change adds front panel insulation (pn 02-4006-02) and a front freezing compartment gasket (pn 02-4005-01).

A retrofit kit is available for prior air cooled models, it is part number **A37983-001**. As in 2002, it includes a louvered left side panel, air filter, air baffle and foam gasket. Front panel insulation (pn 02-4006-02) has been added to the kit.



Bulletin Number: PS - 8 - 2003
Bulletin Date: October 2003

SERVICE BULLETIN

Subject: CSW45 Model Revision

The CSW45 is now being manufactured as a D series. The changes are to the top panel gasket, door gasket and leg gasket

The new part numbers are:

- Top panel gasket 02217293
- Door gasket 02217294
- Leg gasket (lower part of door) 02217367

SERVICE BULLETIN

Subject: Wiring Diagram Change, FME2404R and NME1854R

The wiring diagram for these models has been changed to correct an error. The original diagram wiring resulted in a mis-phased fan relay, which caused early life failure of the relay contacts. The single phase diagram is shown here, the three phase diagram is on the back of this bulletin.

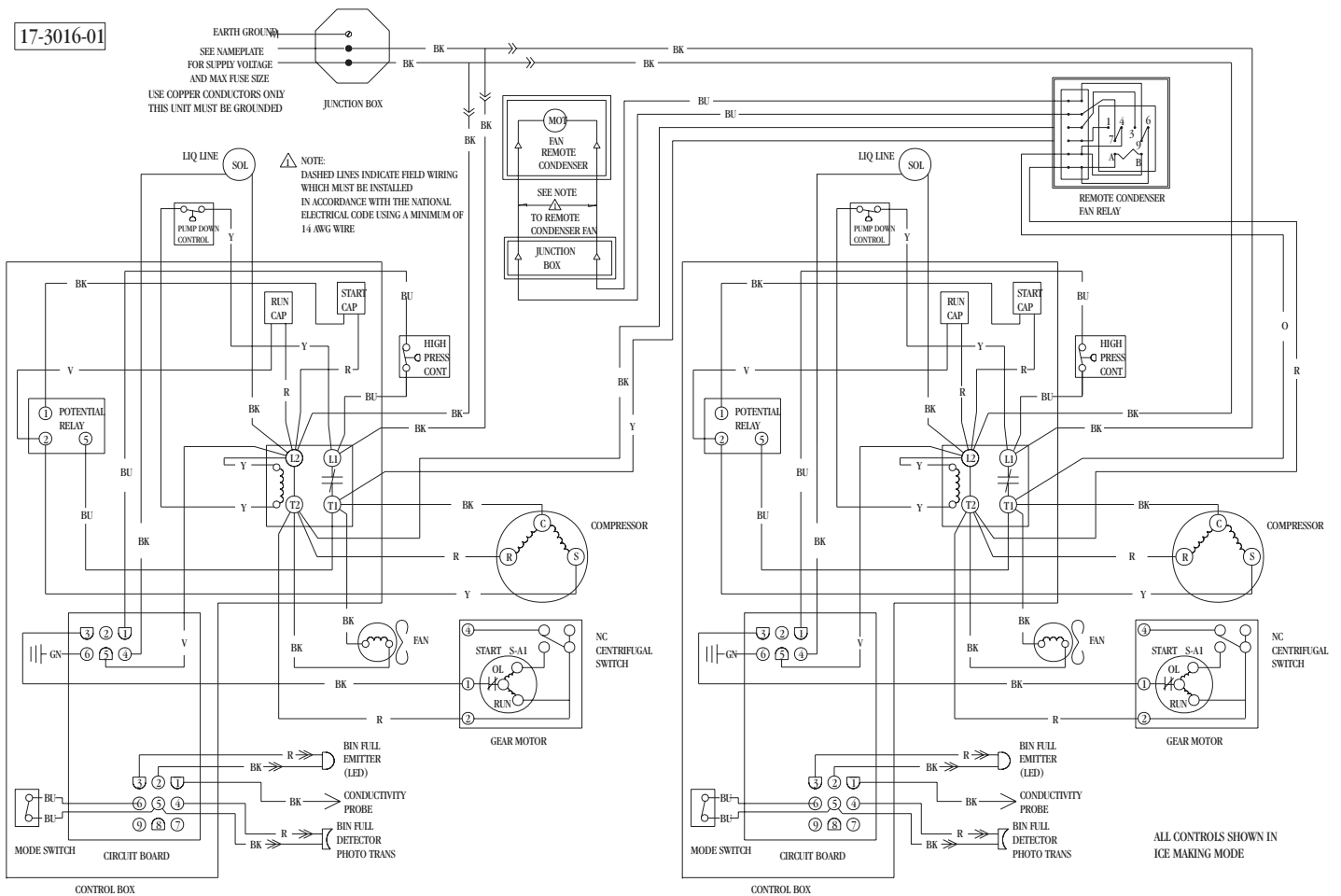

17-3018-01

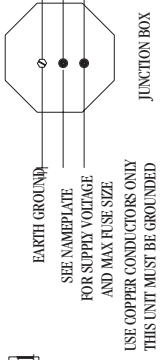

NOTE:
DASHED LINES INDICATE FIELD WIRING
WHICH MUST BE INSTALLED
IN ACCORDANCE WITH THE NATIONAL
ELECTRICAL CODE USING A MINIMUM OF
14 AWG WIRE

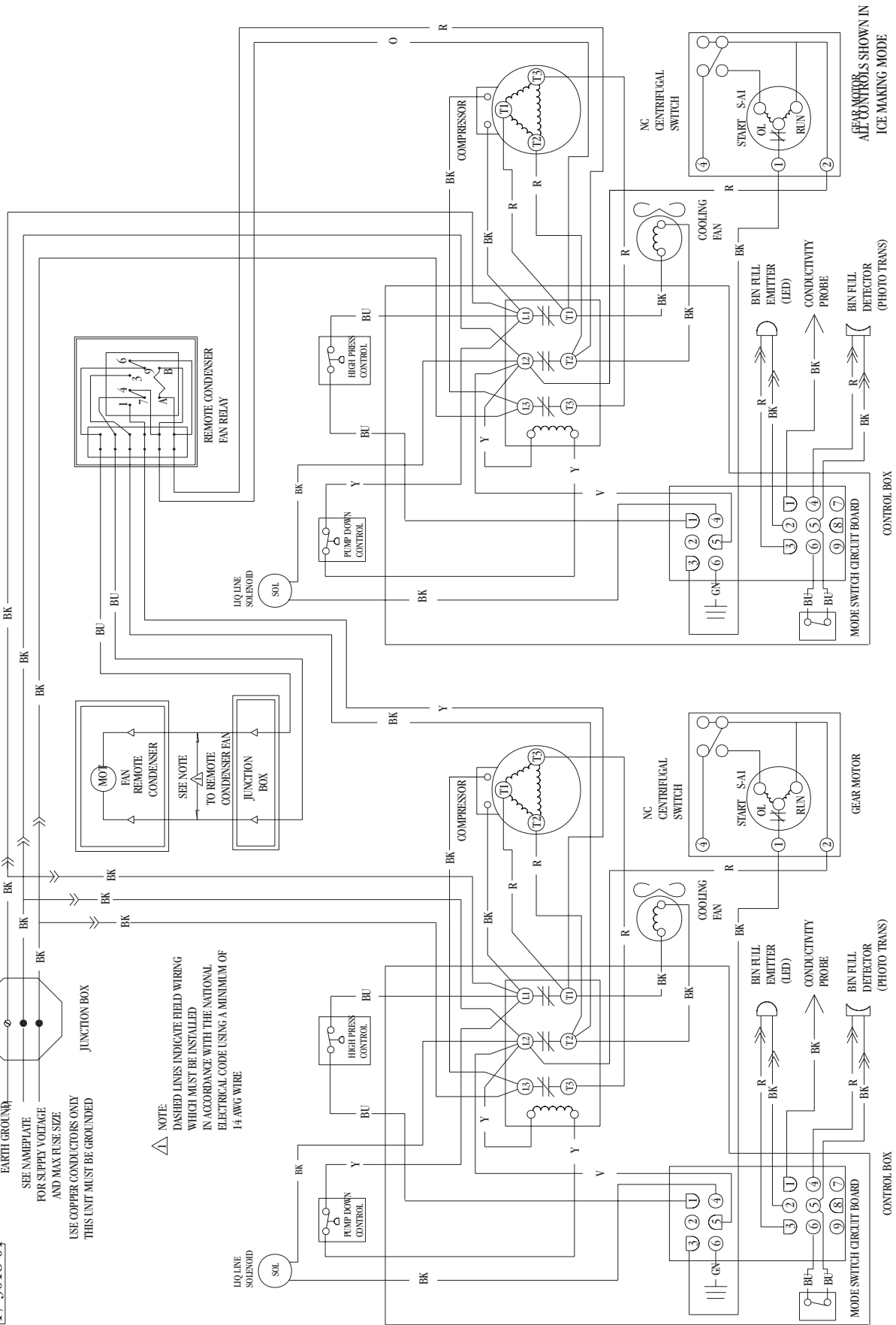



Bulletin Number: PS - 10 - 2003
Bulletin Date: October 2003

SERVICE BULLETIN

Subject: New CM³ Service Controller

Products Affected: All CM³, including CME256, CME306, CME456, CME506, CME656, CME806, CME1056, CME1356, CME1656, CME2006, SCE275, CME686, CME810.

What Has Changed: Added settings for CME1386, CME1686 and CME2086. Eliminated the extra float stems from the kit. New float stems are only required when a controller is installed on a CME256 or CME506 that has a float stem with a screw adjustment (not used since 1/1997).

What To Do: Use the prior controllers on all models (except CME1386, CME1686, CME2086) until they are gone. Stock the 12-2838-23 controller for future use on all CM³ models listed here.

Prior Part Numbers	New Part Number - replaces all prior
12-2838-21 and 12-2838-22	12-2838-23

The new controller contains the settings for any CM³ model. The correct setting is to be selected by the installing technician by looking up the model number in a table (like the one below) and turning a rotary switch to the correct setting.

For Model	Set Switch To
CME256, CME506, CME656	0
CME806	1
CME1056A, CME1056R	2
CME1056W	3
CME1356, CME1656	4
CME2006	5
CME306	6
CME456	7
SCE275	8
European Model CM450SL	9
CME810	A
CME686	B
CME1386	C
CME1686	D
CME2086	E

SERVICE BULLETIN

Subject: MDT2 Wiring Diagram Correction

The wiring diagram in the MDT2's product manual contained an error at the connections to the auger motor capacitor. Here is a corrected diagram.

WIRING DIAGRAM (MACHINE OPERATING)

BU - BLUE
 W - WHITE
 BK - BLACK
 GR - GREEN
 R - RED
 B - BROWN
 LB - Light Blue

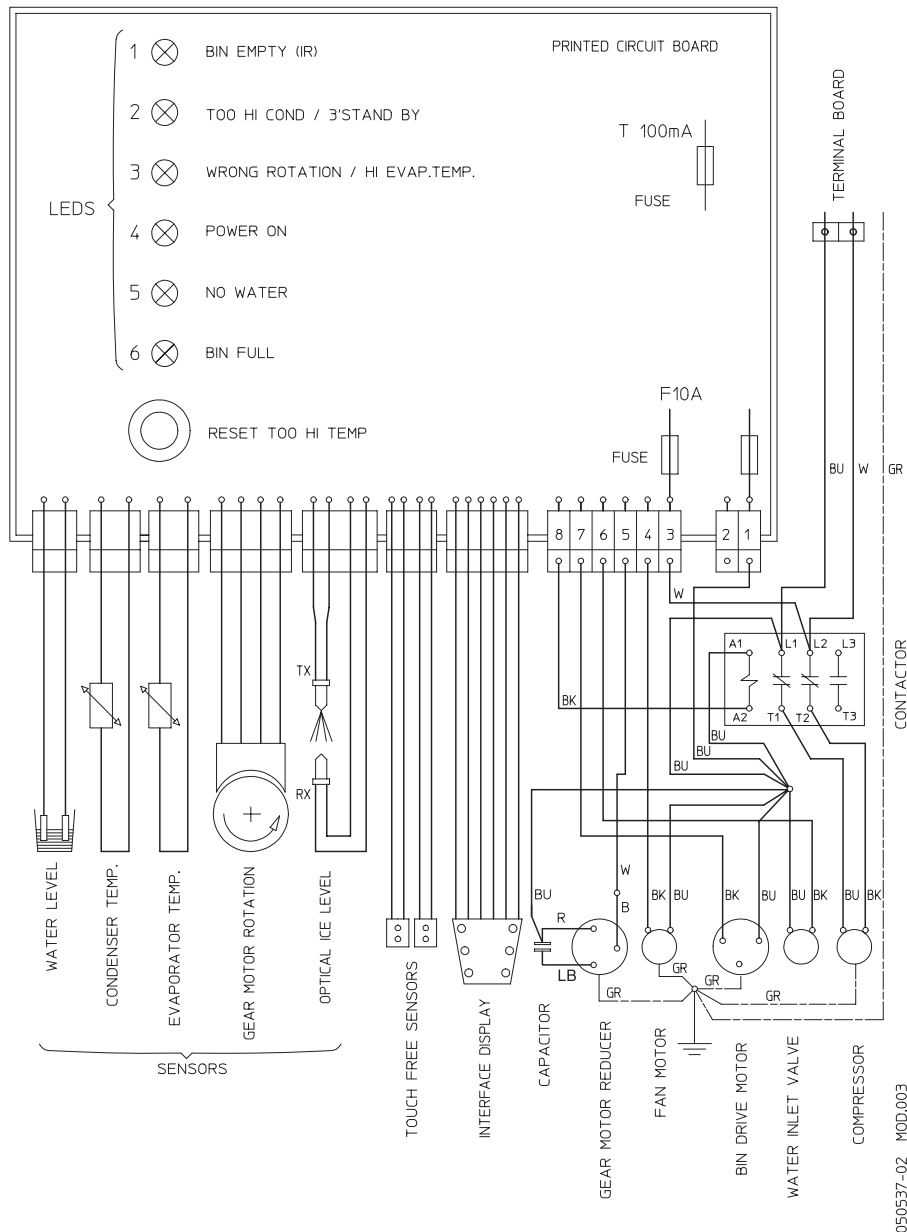



Bulletin Number: PS - 12 - 2003
Bulletin Date: December 2003

SERVICE BULLETIN

Subject: New Auger Drive Motor Service Parts

Models Affected: NME - all, FME - all, MDT5, MDT6, NSE and service replacement assemblies

Scotsman has begun using GE ¼ HP auger drive motors in place of Emerson. The part number of the complete gear reducer or motor does not change and complete motors are interchangeable between Emerson and GE.

. However, there are two new service part numbers:

- Start Switch for GE split phase ¼ HP motor: 12-2430-44
- Rotor bearing for GE split phase ¼ HP motor: 12-2430-49

Use of the GE motor began in December 2003.

To identify the proper service part (start switch or bearing):

1. Check the ice machine model prefix: FM, FME, MTD5, MDT6, NM, NME, ND, NDE, NS, or NSE use this type of drive motor. See the appropriate part list for all others.
2. Check the brand of motor. There are two, Emerson or GE. If Emerson see the appropriate parts list. If GE go to the next step.
3. Check the type of motor. GE PSC motors (used from the early to mid 90s) have a capacitor and use different parts, see the parts list for that model (note that start switches for PSC motors are obsolete). GE split phase motors use the above part numbers.

SERVICE BULLETIN

Subject: MDT2 Front Panel Drain Change

Beginning with serial number 707393-04S, the drain portion of the front panel has been changed. The prior drain was a PVC tube glued to the front panel. The new design uses a screwed together assembly, as shown in the exploded diagram below.

Note: To remove a front panel on the new design, the drain top must be removed so the panel can be separated from the drain fitting.

The part numbers for the new drain system are:

Drain Fitting: F660219-01

O-Ring: F640134-00

Drain Top: F660211-01

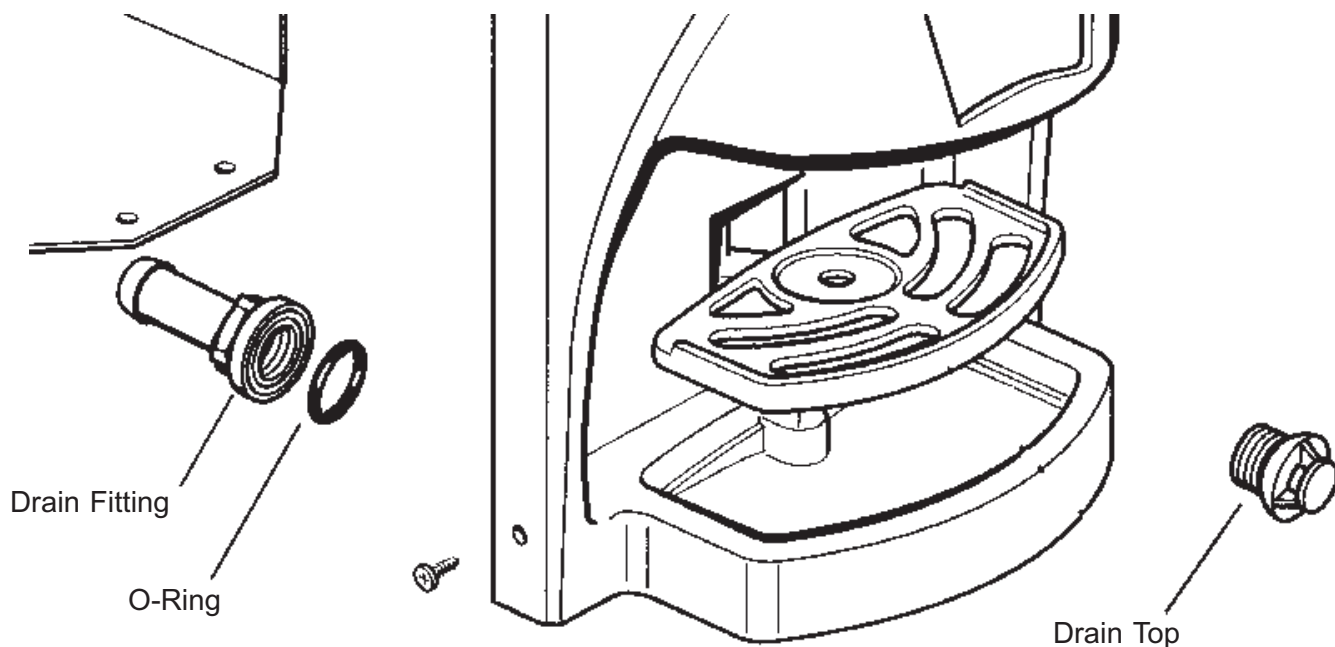

SERVICE BULLETIN

Subject: CME2006 and CME1856 mounting grommet change

Beginning with serial number date code -06S (Dec 03), the mounting grommets under the compressor have been changed.

The new grommet part number is: 03-3843-01. Related parts include: 03-1407-07, flat washer and 18-2300-26 sleeve.

Due to the softer nature of the new grommets, shipping brackets have been incorporated under the back two compressor mounts. These shipping brackets must be removed at start up.

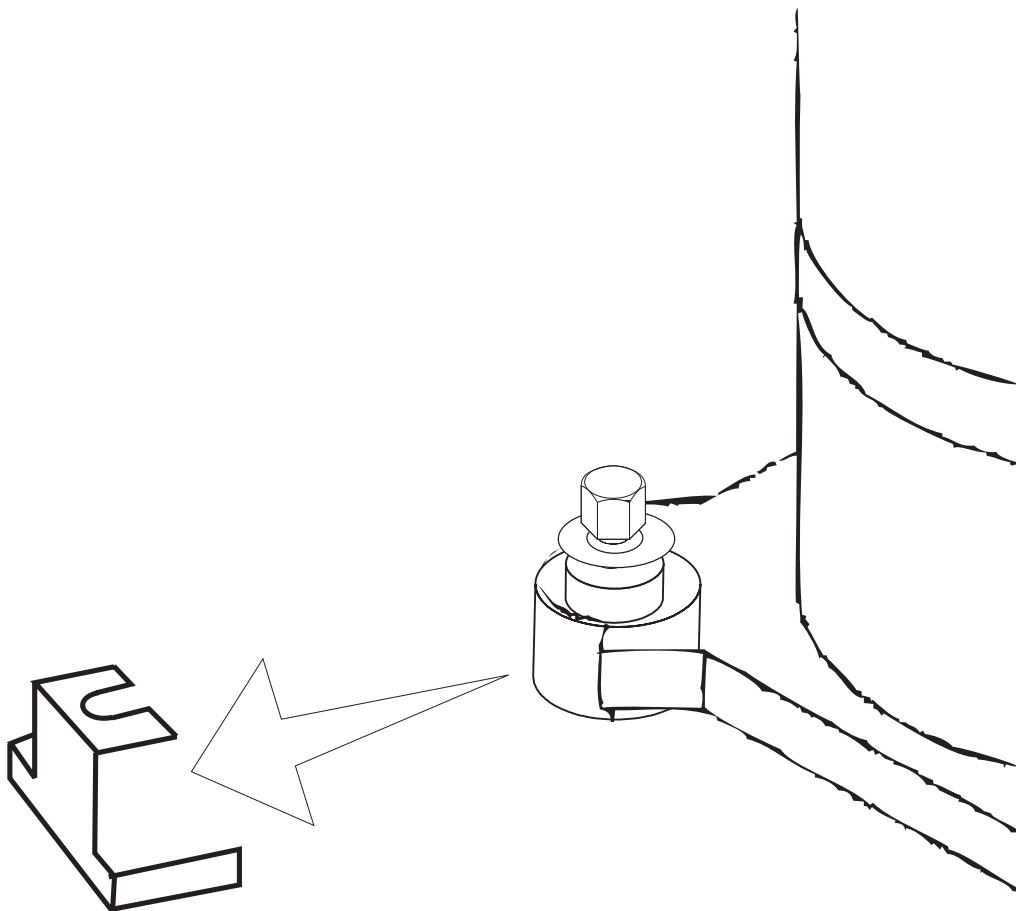



Bulletin Number: PS - 15 - 2003
Bulletin Date: December 2003

SERVICE BULLETIN

Subject: AFE325, AFE400, MFE400, MDT3 and MDT4 Design Change to Gear Reducer

A rubber water shed has been added to the output shaft of the gear reducer used in the above models. It has also been added to the replacement gear reducer assembly.

The part number of the water shed is **13-0941-01**.

The water shed fits over the output shaft, and is put on the shaft below the coupling. It is in this position so it can deflect any water away from the gear reducer output shaft, which reduces the chance of water infiltration.

If placing the water shed on a prior gear reducer, grease should be generously applied to the area under the water shed, to provide a water barrier between the rotating water shed and the gear case cover.

SERVICE BULLETIN

Subject: New Service Auger

Models affected: FD4, FD470, FDE470, FDE474, FD5, MDT3, MDT4, MF400, MFE400, TDE470, SF1 (direct drive)

A new double-flight auger replaces the A29669-001 single-flight service auger. The new auger's part number is: **02-4023-01**.

The new auger is an exact replacement for the prior auger, the only change is the addition of second spiral (flight b) 180 degrees from the first.

The extra flight evens out the flow of ice, balancing the bearing load, and it reduces the high-pitched noise that sometimes occurs during the first few minutes after a restart.

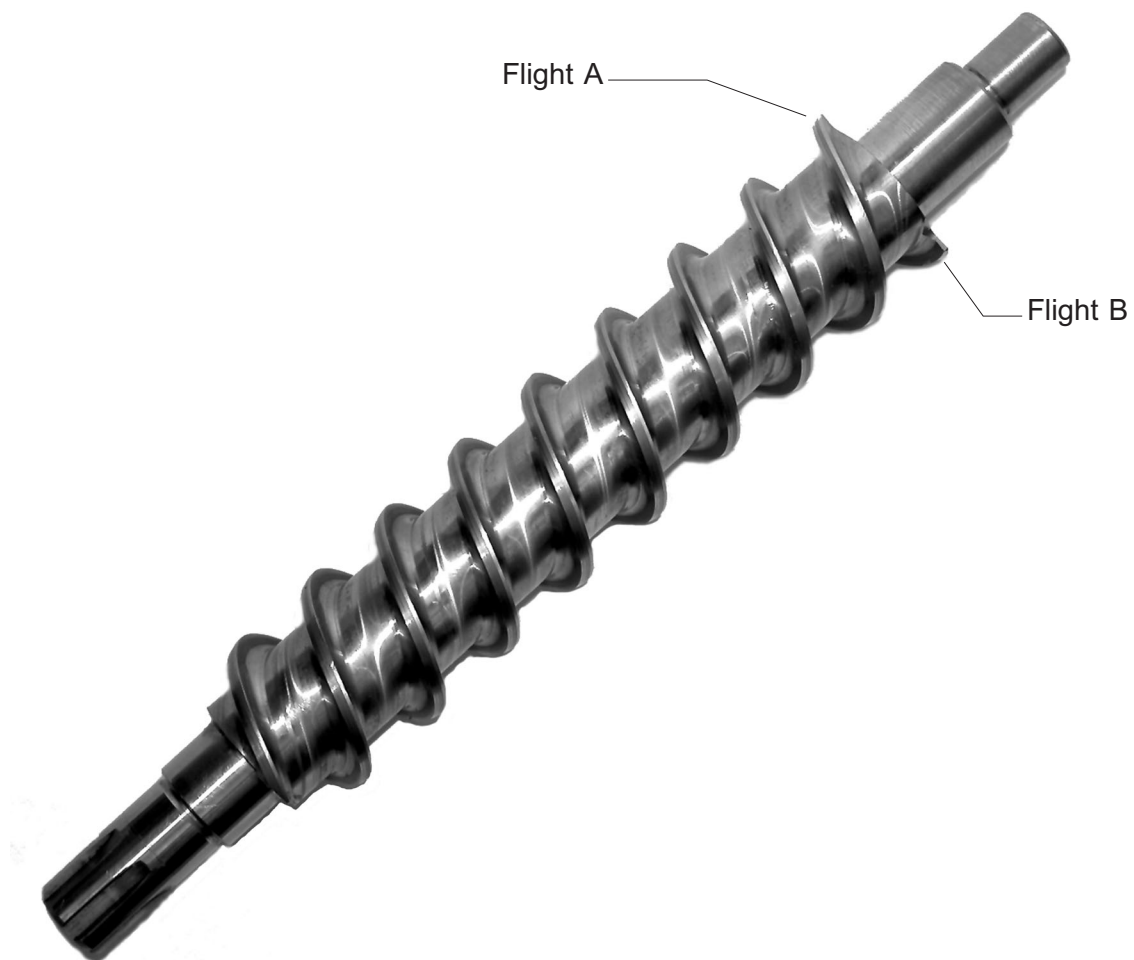

SERVICE BULLETIN

Subject: Service Parts for the Ice Express System (ICS)

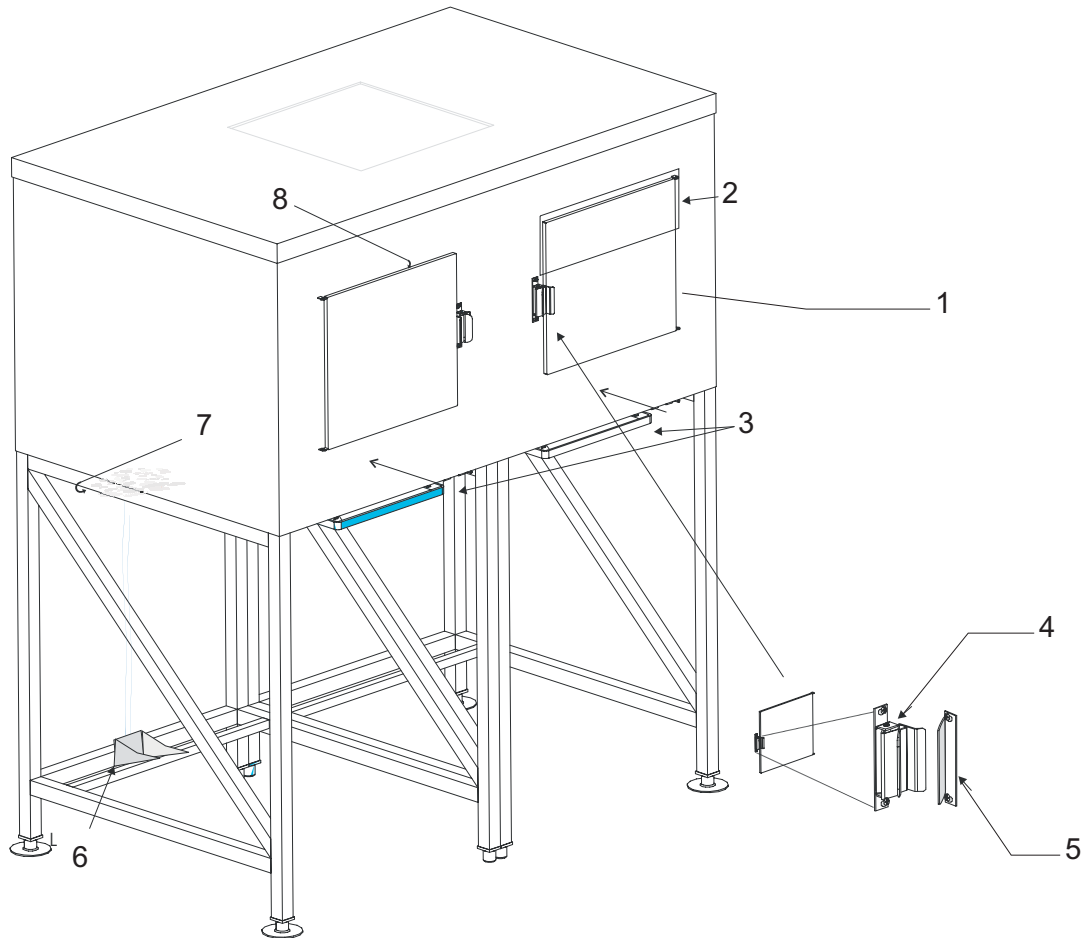

Item Number	Part Number	Description
1	02-4032-09	Door gasket
2	02-4032-10	Baffle
3	02-4032-11	Drop control
4	02-4032-12	Latch
5	02-4032-13	Catch
6	02-4032-14	Lower drain pan
7	02-4032-15	Upper drain pan
8	02-4032-16	Door



SERVICE BULLETIN

Subject: Service Parts for the ICS Cart

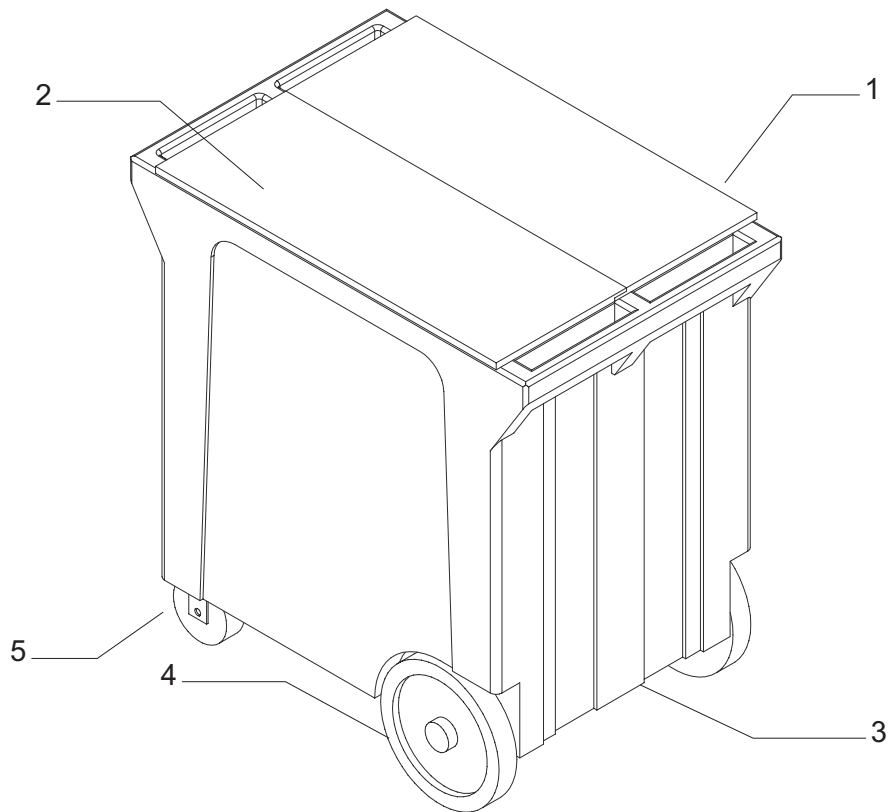

Item Number	Part Number	Description
1	02-4032-01	Hinge Bracket
2	02-4032-02	Lid set
3	02-4032-03	Drain knob
	02-4032-05	Valve & rod
4	02-4032-04	Rear wheel
	02-4032-06	Axle & hardware
5	02-4032-07	Swivel caster, no brake
	02-4032-08	Swivel caster w/brake

SERVICE BULLETIN

Subject: Controller Cover

Affects all versions of models: CME1356, CME1656, CME1856 and CME2006

The above models are now manufactured with a sheet metal cover over the top of the controller.

Service controllers also are now shipped with a cover that should be applied to these models whenever replacing the controller if the machine does not already have a cover installed.

Whenever cleaning or servicing any unit, check to see whether it has a cover over the controller like the one shown below. If it does not, Scotsman recommends installing a cover. A separate part is now available for this purpose. Its part number is **A37480-021**. It mounts over the top end of the controller and is secured by two sheet metal screws. Use the cover as a template and drill two 1/8" holes for the two screws.

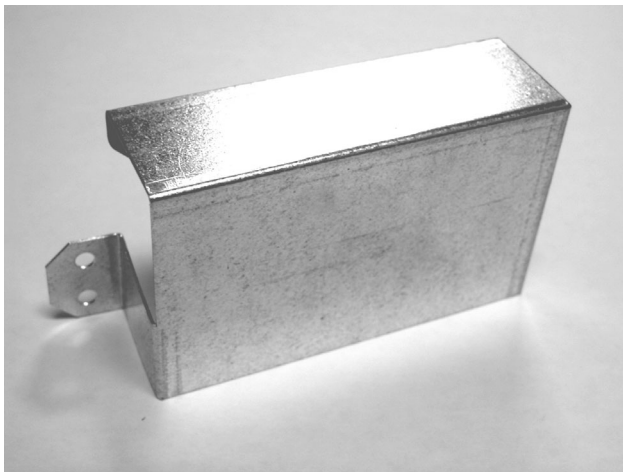

Controller Cover



Cover Installed on Unit

Scotsman is shipping a supply of covers to all Scotsman Distributors and listed service agencies. A supply of covers should be carried by each service person on service calls so a cover may be installed on the unit being cleaned or serviced if one is not already in place. Additional covers may be obtained free of charge from Scotsman, through the local Scotsman Distributor, as needed.

SERVICE BULLETIN

Subject: ERC Remote Condenser Service Parts - supercedes PS-3-2001

The following is a list of the main service parts for the ERC series of remote condensers. Complete parts lists are available in the cuber or flaker they are designed to be connected to.

Model	Fan Motor	Fan Blade	Headmaster (if internal)
ERC101	18-8796-01	18-8800-01	In ice machine
ERC151	18-8796-32	18-8800-01	In ice machine
ERC201	18-8796-32	18-8800-01	In ice machine
ERC301	18-8797-32	18-8800-01	In ice machine
ERC302	18-8796-32	18-8800-01	In ice machine
ERC401	18-8796-32	18-8800-01	In ice machine
ERC402	18-8796-32	18-8800-01	In ice machine
ERC111	12-2651-02	18-8816-01	16-1044-01
ERC211	12-2651-02	18-8816-01	16-1044-01
ERC311	12-2651-01	18-8816-01	16-1044-01
ERC411	12-2651-01	18-8816-01	16-1025-01
ERC611	12-2717-01	18-8820-01	16-1044-01
ERC680	12-2651-01	18-8816-01	in CP
ERC1086	12-2651-01	18-8816-01	in CP
ER2C6810	12-2717-01	18-8820-01	in CP
ERC2086	12-2717-01	18-8820-01	in CP

Fan motor run capacitor: 18-8878-01

Standard (not for CME2006/ERC611) line set end kit (4 parts): MCDQCK

Eclipse line set end kit (6 parts): KTE6

Quick Connect Part Numbers	Liquid	Discharge or Vapor	Suction
Condenser or Ice Machine fitting	16-0850-03	16-0850-01	16-0850-04

SERVICE BULLETIN

Subject: TDE and MDT Ice and/or Water Sensor Labels

The Touch-Free system uses an infrared triangulation position sensor to detect the user's container and activate the dispense system. The sensor is mounted to the unit's splash panel.

The ice and water labels on a Touch-Free unit's splash panel direct the user to the sensor's location. There is a window in the label for the sensor to "see" through. When the units are shipped, an additional clear poly sheet covers the label and the window to protect it from shipping damage. **That poly sheet should be removed at the point of installation.** Although dispensing will work with the poly sheet in place, activation with clear cups and pitchers will improve when the poly sheet is removed.

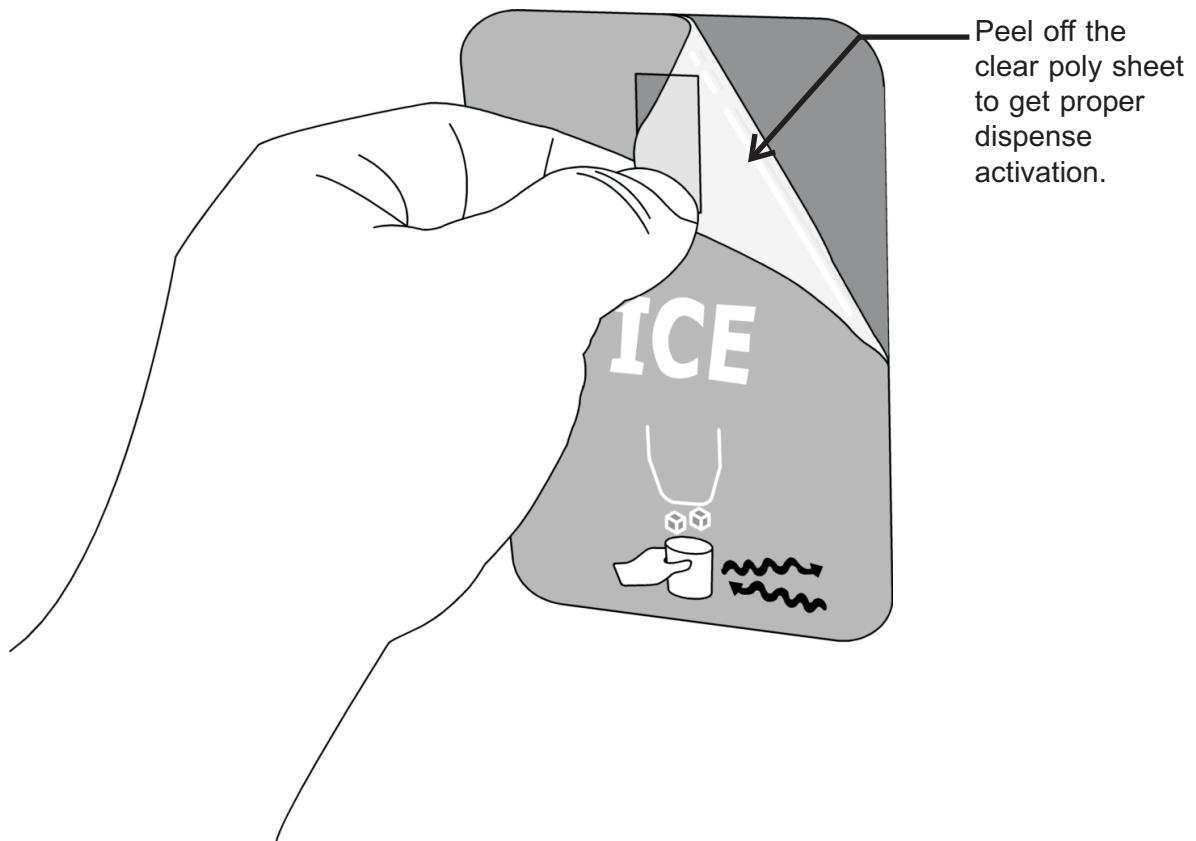



Bulletin Number: PS - 7 - 2004
Bulletin Date: June 2004

SERVICE BULLETIN

Subject: CME306 and CME456 C Series

All models of the CME306 and CME456 have been changed to a C series. Example: CME456AS-1B was the prior model number; CME456AS-1C is the new model number.

The new model number is due to a change in the thermostatic expansion valve.

The part number for the new TXV is: **16-1115-21**. This valve must be used with the C series, and it can be used on the prior series of the CME306 and CME456. However, the new valve is currently not approved for use in any other Scotsman product, and is not cross-referenced.

The new valve has stainless steel sweat fittings that are internally coated with copper. It can be brazed with silphos (2% silver) but the heat must be applied primarily to the copper tubing. To braze, start heating the copper tube near the TXV connection, get it red hot and then briefly heat the TXV connection. Apply the brazing rod when the joint is hot. Heating time will be about 3 to 5 times longer on the copper tubing than the TXV stub. A heat sink is not recommended. A nitrogen purge is mandatory.

Fan Motor Brackets: The 12-1681-03 and 12-1681-04 fan motors used on the CME306 and CME456 are now produced by GE. They are slightly shorter than the prior fan motor, so they require new mounting brackets to correctly position the fan blade. The mounting bracket for the GE motor in these two models is part number A38480-001.

Water Cooled Model: Another change is the addition of a CME456WS-32B and CME456WS-32C model.

CME456WS-32C information:

- Basic Electrical: - - - - - 208-230 volts, single phase. 60 Hz
- Minimum Circuit Ampacity: - - - - - 9.2
- Maximum Fuse Size:- - - - - 15
- Replacement compressor part number: - - - - - 18-8839-23
- Replacement overload for compressor: - - - - - 18-8839-50



Bulletin Number: PS - 8 - 2004

Bulletin Date: June 2004

SERVICE BULLETIN

Subject: Serial Number Format Change

Scotsman has been using a number-letter combination serial number & date code since 1972. Starting now, a new serial number format and date code system is in effect. As before the date code lists the month and year the unit was manufactured, but now they are represented by the last two digits of the year and the two digits of the month.

The new serial number format begins with the 4 digit date code, continues to a fixed Scotsman number (1320) and ends with a six digit number.

New serial number example: **04051320123456**

0405 is the date code, in YYMM format. - This example is May, 2004. Changes monthly.

1320 is the Scotsman identifier. - This will not change.

123456 is the serial identifier. - This will change with every unit.

SERVICE BULLETIN

Subject: New Vending Control Panel for MDT2

The dispensing switch panel for the MDT2 has been changed. The label-over-push buttons system has been changed to a membrane switch panel with separate light board.

Part number F060613-00 is a retrofit kit that replaces the existing dispensing PC board, the label and the mounting box with a new assembly.

F620483-00 is the membrane switch panel, and F620483-03 is the LED display board. They can be used only on units that were originally equipped with membrane switches. Prior models can use the kit.

The ice and water dispensing label F650753-01 has been changed to improve its durability and will remain available.



SERVICE BULLETIN

Subject: New Ice Storage Bin, BH801

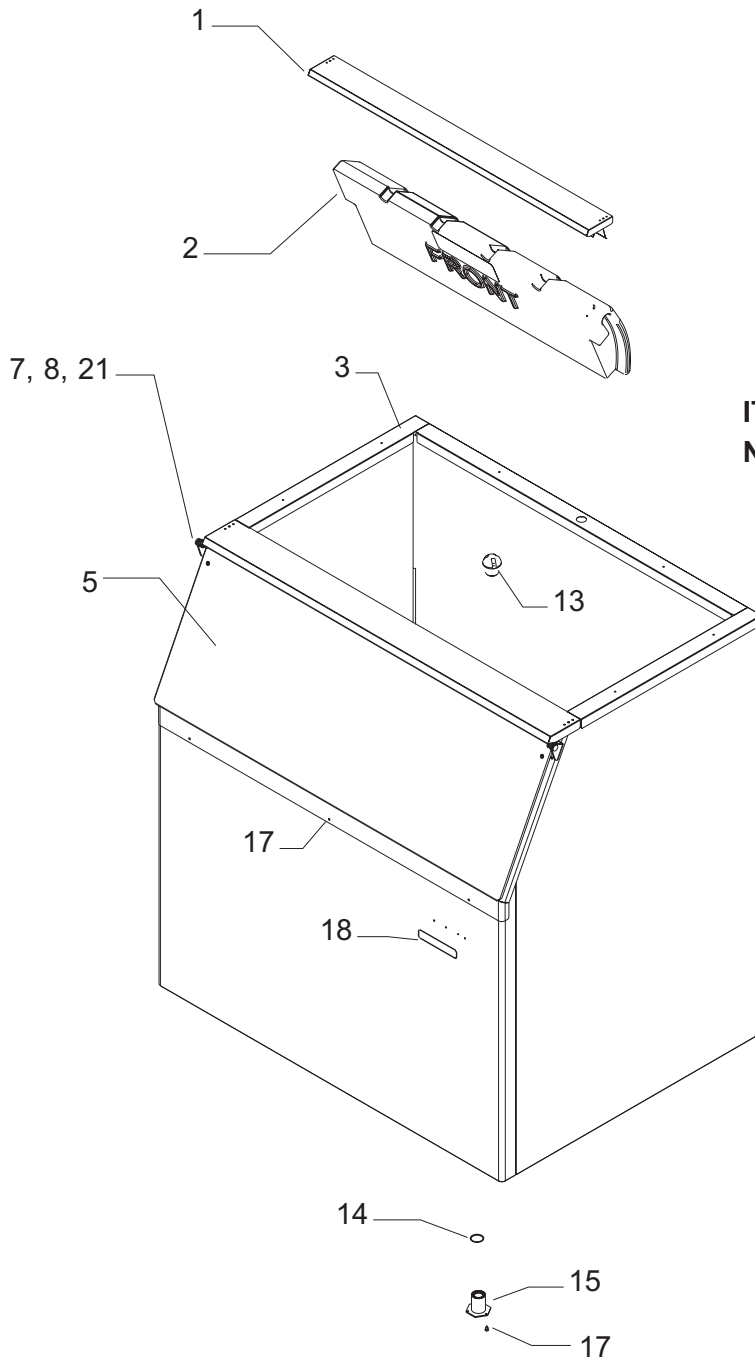

ITEM NUMBER	PART NUMBER	DESCRIPTION
1	A38434-001	Canopy
2	A38476-001	Baffle
3	19-0503-04	Gasket order per foot
4	A37640-021	Door Frame,
5	A32419-020	Door, incl 5a, 6, 21, 22
5a	02-2881-02	Drip molding
6	13-0595-00	Door Gasket (10')*
7	A32396-002	Hinge Rt.
8	A32396-001	Hinge Left
9	02-2380-01	Hinge Bushing
10	02-2380-02	Hinge Spacer
11	02-2806-01	Shoulder Screw
12	03-1539-09	E-Clip
13	02-2809-02	Drain Top
14	13-0617-09	O-Ring
15	02-3201-01	Drain bottom
16	KLPE	Legs, painted set of 4
	KLPS	Legs, S.S. set of 4
17	03-1404-07	Screw - frame to bin
18	03-1419-09	Screw - hinge to frame
19	15-0808-01	Emblem
20	03-1418-24	Screw - hinge to door
21	A32546-001	Door Hinge Lft
22	A32546-002	Door Hinge Rt.

SERVICE BULLETIN

Subject: New motor and motor housing for 1/10 HP flaker gear reducers

The auger drive motor for the 1/10 HP gear reducer has been changed. The motor now has ball bearings at both ends. Production of AFE400s & AFE325s with this change began in late September. One service part is affected. The prior motor's sleeve bearing was supplied as part of the motor housing. A new motor housing kit that includes both the prior motor housing (BLUE) and the new motor's housing (GREEN) is now available. Both include new bearings. The kit number is: **A38487-001**.

Both of the new motor's bearings are part number 02-1501-00.

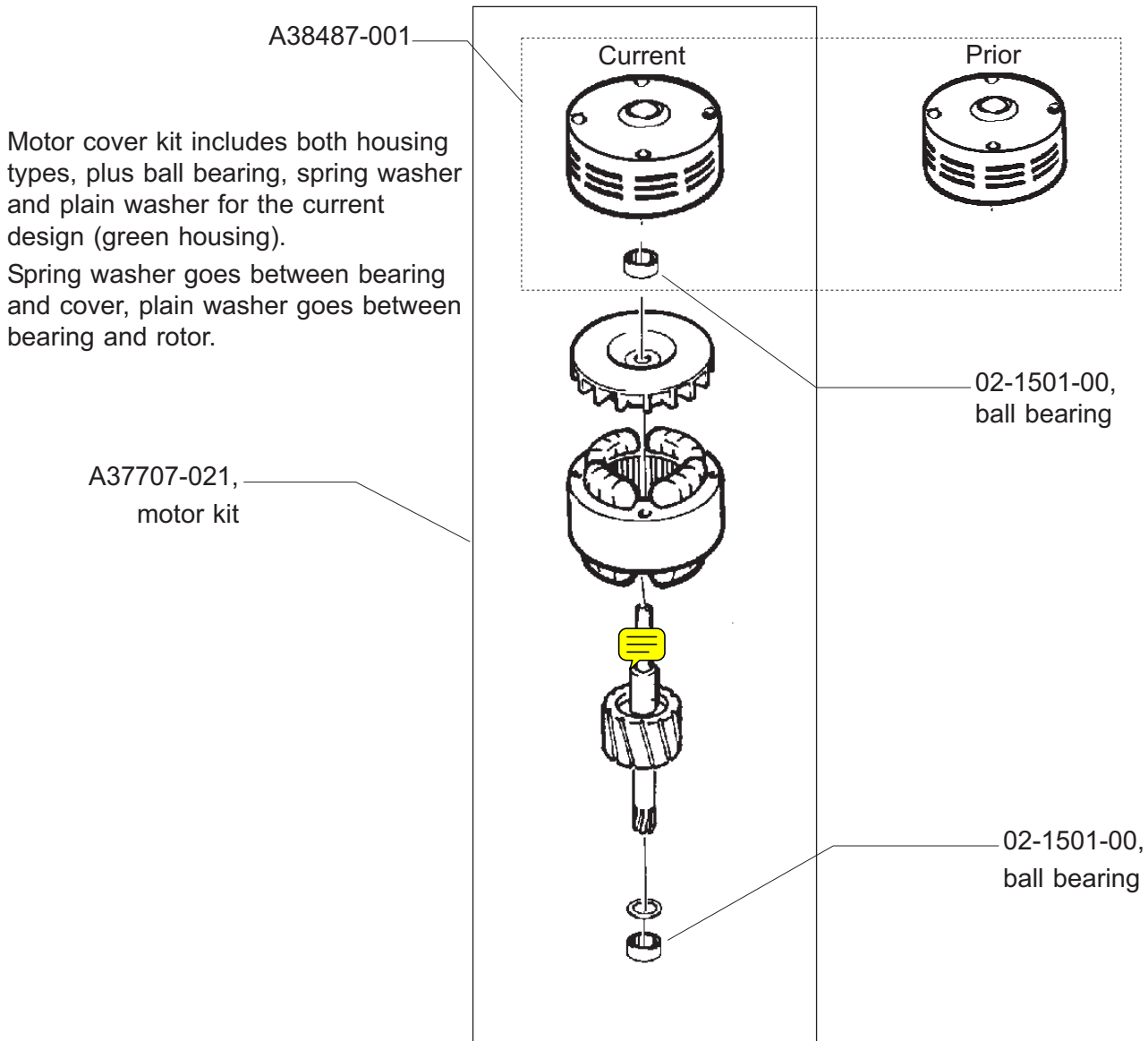



Bulletin Number: PS - 2 - 2005
Bulletin Date: January 2005

SERVICE BULLETIN

Subject: MDT Portion Controlled Dispensing Kit

A time-delay relay kit is now available for addition to the MDT3, MDT4, MDT5 and MDT6. The purpose of the kit is to limit the amount of ice dispensed per activation.

The kit number is **KPC-MDT**. The kit includes a time delay relay and potentiometer. When the Touch-Free dispense system is activated, the time delay relay powers the dispense motor and / or door solenoid for a limited time. That time is adjustable to accommodate the cup or glass being used.

A typical application for the kit is a high volume dispense situation where the amount of ice spilled is unacceptable. Spilled ice is usually caused by overfilling the container during dispensing, followed by the extra ice being dumped into the unit's drip tray. Adding the kit allows the amount of ice per dispense to be set to match the amount an individual needs, so there is less waste. This is especially helpful on the MDT6, which is a high volume, rapid dispensing model.

The KPC-MTD includes a potentiometer for time dispense adjustment.

The kit does not apply to the MDT2C12, which already has a portion control system.

SERVICE BULLETIN

Subject: CM³ Controller Revision Change

The controller used in SCE275, CME256, CME306, CME456, CME506, CME656, CME686, CME806, CME810, CME1056, CME1356, CME1386, CME1656, CME1686, CME1856, CME2006 and CME2086 has been changed. The service controller, 12-2838-23, has also been changed.

The change is a revision to the existing controller. No part numbers change. The new revision, number 9, **adds a new diagnostic procedure**. All other prior features remain as they were.

New Diagnostic

The new diagnostic procedure checks two functions of the controller:

1. At the beginning of the diagnostic, all the controller's relays are automatically switched on in a particular sequence for a short time to confirm that power is going to the electrical component and that the component is operating.
2. At the end of that test the water level sensor is checked. The green light display on the controller changes as the float stem is moved up and down in the sensor.

Electrical Component Test Sequence:

1. **Water inlet valve test.** Verifies that the water inlet solenoid valve opens and water fills the sump. Some water may overflow into the bin.
2. **Water Pump test.** With water in the sump from the prior test, the pump starts and circulates water.
3. **Purge valve test.** Purge valve opens to discharge water. No effect on overflow models.
4. **Compressor test.** Compressor starts, hot gas valve open for short time.
5. **Harvest bypass valve test.** Compressor on, check valve remote systems verify that the harvest by-pass valve opens.
6. **All off test.** Verifies that the relays open.
7. **Hot gas valve test.** Verifies that the hot gas valve opens.
8. **Fan motor test.** The fan motor is switched on to verify its operation.

To start the diagnostic process

1. Push and hold the Off button until the unit shuts off.
2. Push and hold the Off button again until the Purge indicator lights (green lights) switch on.
3. Push and hold the Clean button until the bin full light starts to blink, that starts the diagnostic. The test will begin and end automatically.

Part One, Electrical Component Test. It can be confirmed visibly, audibly or by volt or amp meter

		Model Type - See Notes Below			
Test	Seconds On	A. Air or Water Cooled	B. Check Valve Remote	C. Pump Down Remote	D. Eclipse
1	30	Water inlet valve	same as A	same as A	same as A
2	10	Water Pump	same as A	same as A	same as A
3	10	Pump, Hot gas valve (and purge valve when used)	same as A	same as A - but no purge valve	same as A, but vapor inlet valve in place of hot gas valve, and adding cond. bypass and receiver inlet valves
4	5	Hot gas valve, compressor	same as A	same as A, plus the liquid line valve	same as A, but vapor inlet valve in place of hot gas valve, and adding cond. bypass and receiver inlet valves
5	15	Compressor	same as A (plus fan motor), also harvest by pass valve	same as A (plus fan motor), also liquid line valve	same as A (plus fan motor)
6	5	None	same as A	same as A	same as A
7	10	Hot gas valve	same as A	same as A	same as A, but vapor inlet valve in place of hot gas valve, and adding cond. bypass and receiver inlet valves
8	5 or 10	Fan motor (10 secs)	By pass valve (5)	Liquid line valve (5)	none

Results:

- If all the components operated as listed, the controller passed the test.
- If a component does not operate when it should, check its electrical connection. Check for open circuit or physical damage. If OK, refer to the product's wiring diagram and repeat the test with a voltmeter at the controller end of the harness. Check with one voltmeter lead on the proper terminal and the other to ground.
- If no voltage is present during the suspect component's turn in the second test, the controller needs to be replaced. If there is voltage at the controller end but none at the component, the harness needs to be replaced.

Notes:

- **Check Valve Remote** models are the CME456R, CME1056R, CME1356R, CME1656R and the CME2006R.
- **Pump Down Remote** models are the CME506R, CME656R and the CME806R.
- **Eclipse** models are the CME686, CME810, CME1386, CME1686 and the CME2086.
- Water cooled and Eclipse models in test 8 have nothing operating.

Part Two: Water Level Sensor Test. Covers: All Models: The water float's position is indicated by the green lights on the controller. Refer to this table:

Column One: Float Position	Column Two: Green Lights On	Column Three: Jumper Test
Over filled or dry sump (float all the way up or down), all of the slot is visible	Freeze, Harvest, Clean and Off	Unplugging sensor harness from #2 on controller.
Full sump	Harvest, Clean and Off	Jump pins one (bottom) and two
Mid position	Clean and Off	Jump pins one (bottom) and three, and pins one and two
Sump needs refill or end of freeze	Off	Jump pins one and three

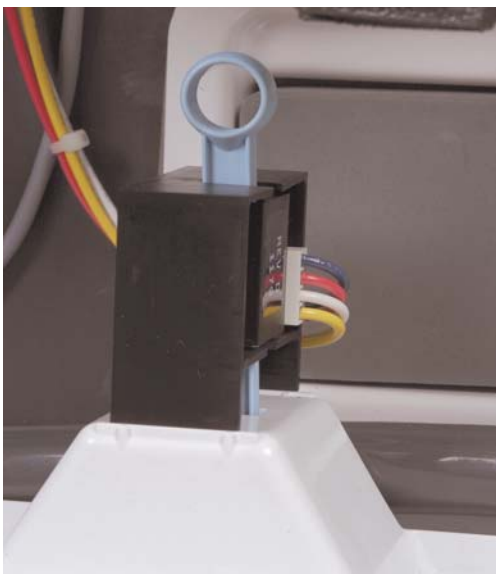

Water Level Sensor Test.

Example:

Float depressed or at low point, results in only the Off light on.



To Test: Move the float stick slowly up and down and observe the light display on the controller.

Results:

- If the lights change as listed in column two, the system has passed the test.
- If the test failed, perform the jumper test in column three. If that test results in the lights on as listed in column two, the controller is OK but the sensor or harness needs to be replaced. The harness can be checked the same way by unplugging the connection at the sensor and testing again.
- If the lights do not glow as indicated after the jumper test, the controller has failed and needs to be replaced.

Overall Notes:

- **Water valve test** may result in overfilling the sump, causing water to spill into the bin.
- **Test will stop** after 60 seconds of no input or whenever the Off button is pushed. Bin full light will stop blinking when the test is complete.

SERVICE BULLETIN

Subject: New Pulleys for MAR1400 and MAR2000

The motor and gear reducer pulleys for these two models has changed. The V belt between them has also changed. The new pulleys are cast iron, the prior ones were aluminum. The prior V belt (M650422-22 (Z33) is still available as are the pulleys.

The pulleys must be used with the correct V belt and cannot be mixed within a unit.

New Pulleys

	Drive motor pulley, standard	Drive motor pulley for thin ice	Gear reducer pulley	SPZ V Belt*
MAR1400	M650879-05	M650879-09	M650879-10	M650878-01
MAR2000	M650879-07	not used	M650879-10	M650878-01

* Toothed type.

Prior Pulleys

	Drive motor pulley, standard	Drive motor pulley for thin ice	Gear reducer pulley	V Belt
MAR1400	M734597-31	same	M734597-27	M650422-22** M650422-18***
MAR2000	M734597-46	not used	M734597-27	M650422-22** M650422-18***

** Z33 Used with VF/W30/63 gear reducer.

***Prior belt is Z35, Use with prior VF 30/63 gear reducer

Fiber Key Update

There are two fiber keys that connect the gear reducer drive shaft to the refrigerated drum. These are item 22 of page 5 in the parts list. The update is that MAR1400 and MAR2000 use different keys:

- MAR1400 key part number M741092-04
- MAR2000 key part number M741092-03



Bulletin Number: PS - 5 - 2005

Bulletin Date: April 2005

SERVICE BULLETIN

Subject: AFE325 and AFE400 Model Number and Compressor Change

The model series number of these ice machines has been changed due to the introduction of a new compressor. The new model numbers are:

- AFE325AS-1B
- AFE325AS-6B
- AFE400A-1C
- AFE400W-1C
- AFE400A-6C
- AFE400W-6C

All the above use a Danfoss compressor. The new service compressor's part numbers are:

- 18-8918-21 for 60 Hz (-1)
- 18-8918-26 for 50 Hz (-6)

The above service compressors are kits that include the starting components and tubing to replace the prior Tecumseh (service compressors 18-8746-21 and 18-8746-26 will be discontinued).

Starting components for the new compressors:

- 60 Hz start relay w/overload: 18-1903-60
- 60 Hz start capacitor: 18-1901-60
- 50 Hz start relay w/overload: 18-1903-61
- 50 Hz start capacitor. 18-1901-61



Bulletin Number: PS - 6 - 2005

Bulletin Date: May 2005

SERVICE BULLETIN

Subject: Fan motor bracket change

The fan motor mounting bracket for the FME800, FME804, NME650 and NME654 has been changed.

The prior part, 02-2378-02, will no longer be used for production or as a service part.

The new part number is **A38850-001**, which is a sheet metal type bracket. In new units it will be connected to the fan shroud with 1/4 - 20 screws, pn 03-1645-01.

When replacing a prior bracket, use the original #8 screws but place a #8 flat washer under the head of the screw to prevent it from pulling through the bracket's clearance hole.

Production of NME654 with the new bracket began with serial number: 05051320012877

Production of FME804 with the new bracket began with serial number: 05051320013382

SERVICE BULLETIN

Subject: Ice Machine Sanitation After a Boil Water Order

The ice machine should be shut off during a boil water order unless the ice is not used in drinks or for human consumption.

After the boil order has been lifted, the ice machine and its water supply have to be re-sanitized.

Materials Needed:

- Ice machine cleaner
- Locally approved sanitizer
- New, small sprayer, similar to those used for gardening
- Clean cloths
- Clean Bucket

Definitions

- Food Zone: Compartment where ice is made. Includes the water system and surrounding panels.
- Drop Zone: Chute or slot in base where ice is discharged.
- Water System: Any place in the machine, excluding the condenser, that water or ice touches.

Basic Post Boil Order Procedure - Refer to ice machine manual or cleaning instructions for details specific to that model.

1. Restart the ice machine and operate it for 2 hours. This insures that clean water has gone through the plumbing to the ice machine. Disregard this step if the machine has been making ice for at least two hours after the boil water order has been lifted.
2. Change the water filter cartridge(s). If there are no water filters, go to step 4.
3. Operate the ice machine for an hour, then shut it off.
4. Discard all ice in the ice storage bin.
5. Remove ice storage bin baffle and set aside.
6. De-scale the ice machine's water system and the inside of the storage bin per the instructions on the unit's cleaning label or in the product's manual. Generally this requires mixing ice machine cleaner, pouring it into the reservoir of the ice machine, allowing it to circulate for a certain time and then flushing it out. On a bin the liner walls are washed with the ice machine cleaner solution.
7. Repeat the scale removal process with sanitizer. The reason for using ice machine cleaner is to get any scale off the surfaces so that the surface can be sanitized. Use the sprayer for easy coverage of interior food zone parts. Thoroughly spray or wash the entire food and ice drop zone with the sanitizing solution. Use a locally approved ice machine sanitizer. A potential sanitizing solution can be made by mixing one ounce of household bleach to two gallons of warm water.

8. Sanitize the ice storage bin by thoroughly spraying the interior with the sanitizing solution. Include the baffle and the inside of the bin door.
9. Allow parts to air dry.
10. Place all parts removed back to their original places and restart the ice machine.

Ice Machine Sanitation after Submersion

Because of very significant costs to replace most parts and the likely contamination of the ice machine cabinet, replacement with a new machine is recommended when an ice machine has been submerged in flood water.

All electrical components except for the hermetic compressor must be replaced. This includes fan motors, relays, control boards, solenoid coils, pump, capacitors, PTCRs, contactors, and sensors.

In addition, if the machine is a flaker, the gear reducer and the auger bearings must be replaced.

If the storage bin has been submerged, it must be replaced.

If the ice machine cabinet, base or freezing compartment has been submerged, it must be replaced.

All wiring must either be replaced or thoroughly dried and the terminals cleaned.

Sanitation must be thorough. All water system parts must be removed, de-scaled and then sanitized. That includes covers, brackets, deflectors, hoses, water distributors.

Follow the boil order procedure after all components above have been changed and sanitized.

Note: None of the above is covered by any warranty nor is there any guarantee that even if all the steps are followed, a machine or bin that has been submerged can be reconditioned adequately to make ice fit for human consumption. Replacement is strongly recommended.

SERVICE BULLETIN

Subject: Setup of Nugget Ice Machines on Ice and Beverage Dispensers

General information by dispenser brand, specific instructions provided with each kit:

Scotsman ID150, ID200 and ID250

- Add correct adapter kit (see Scotsman sales literature)
- Add thermostat kit KDIL-N-ID2 with ID200 and ID250. Not used on ID150.
- Add KNUGDIV diverting plate kit
- Keep restrictor plate, adjust to 1.5" opening
- Adjust agitation time to 2 seconds on every 3 hours

Cornelius

- Add correct adapter kit (see Scotsman sales literature)
- Change agitator to R629088514 when using ED150 w/cold plate
- Add thermostat and ice slide kit KDIL-N-200 when used with ED/DF200
- Add thermostat and ice slide kit KDIL-N-250 when used with ED/DF250
- Add KNUGDIV diverting plate kit
- Keep restrictor plate, adjust to 1.5" opening
- Adjust agitation time to 2 seconds on every 3 hours

Lancer - nugget ready dispensers only

- Use Lancer adapter with Nugget-ready Lancer dispenser
- Use Lancer thermostat bracket, included with Lancer adapter
- Add Scotsman thermostat kit KDIL-N-L
- Route thermostat cap tube per Lancer instructions - see page 3
- Position ice machine flush with right side of dispenser
- Adjust agitation time to 4 seconds on every 150 minutes

SerVend

- Install components as recommended by SerVend - if an ice level control is added, connect contacts in series with mode switch of ice machine.

NME654, NME954 and NME1254 General Information:

- Added bin control contacts to be wired in series with the mode (toggle) switch.
- Thermostat must not shut unit off until ice is in full contact with cap tube or bracket
- TXV bulb must be tight to suction line
- Water level in reservoir should be checked

Adapters: All installations require an adapter plate. The adapter plate covers the top of the dispenser, has a drop zone hole for the ice to go through and supports the ice machine. Some adapters include a baffle to keep the ice from forcing its way out the front during dispensing.

Kits: Additional kits are required for proper operation. See the table for kit applications.

- KNUGDIV – diverter kit for Scotsman and Cornelius dispensers. Installed in the ice chute area.
- KBT bin tops. Adapters for Scotsman and Cornelius dispensers.
- KDIL-N-ID2. Kit to add a bin thermostat to ID200 and ID250
- KDIL-N-200. Kit to add a bin thermostat and ice slide to 200 size Cornelius ice beverage dispensers. Also includes KNUGDIV
- KDIL-N-250. Same as above except fits the 250 sized models.
- KDIL-N-L. Kit to add a bin thermostat to the special nugget capable Lancer dispenser.

Adjustments: All the dispensers have automatic agitation to keep the ice stirred up. If agitation is too frequent, the nugget ice will be damaged and will become difficult to dispense. The Scotsman and Cornelius dispensers need to be set to 2 seconds on every 3 hours and the Lancer needs to be set to 4 seconds on 150 minutes off.

The Scotsman and Cornelius dispensers also have a restrictor plate at the outlet of the hopper. That plate should be adjusted to be 1.5” open to limit the speed the nugget ice flows out during dispensing.

KDIL Overview: The KDIL-N-ID2 kit includes a thermostat, thermostat mounting bracket and cap tube mounting bracket.

The KDIL-N-200 and 250 kits include a thermostat, thermostat mounting bracket, cap tube mounting bracket and ice slide. The cap tube mounting bracket is also the baffle that mounts to the adapter. The ice slide snaps into the slot in the bottom of the ice hopper that allows ice to flow to the cold plate. The thermostat is wired in series with the ice machine mode switch and mounts in the control box. A KNUGDIV kit is also included.

The KDIL-N-L kit includes a thermostat and a mounting bracket for the control box. A separate part from Lancer is also required. That part includes an ice machine mounting plate and a bin thermostat cap tube bracket. The thermostat in this kit is also wired in series with the mode switch.

Kit and Adapter Applications

	NME654	NME954	NME1254
Scotsman ID150	KBT42, KNUGDIV	KBT42, KNUGDIV	does not fit
Scotsman ID200 or ID250	KBT46*, KDIL-N-ID2	KBT46*, KDIL-N-ID2	KBT44, KDIL-N-ID2
Cornelius ED/DF150	KBT42, plus agitator R629088514*	KBT42, plus agitator R629088514*	does not fit
Cornelius ED/DF200	KBT46*, KDIL-N-200	KBT46*, KDIL-N-200	KBT44, KDIL-N-200
Cornelius ED/DF250	KBT46*, KDIL-N-250	KBT46*, KDIL-N-250	KBT44, KDIL-N-250
Lancer (must have N in part number) 30" model	KDIL-N-L and Lancer part number 82-3491		

* Includes KNUGDIV

Instructions: Complete instructions are included with all kits and adapters.

Replacement Parts: Thermostat: part number 11-0353-23

Lancer Bin Thermostat Bracket and Cap Tube Routing

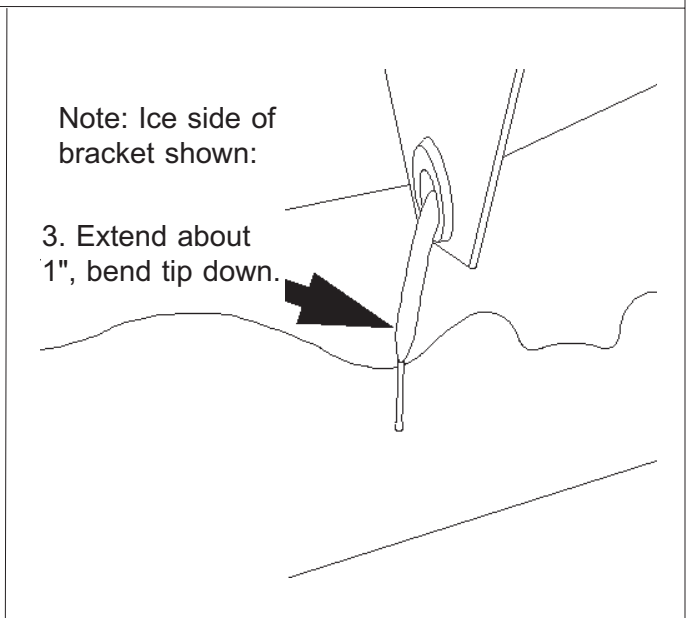
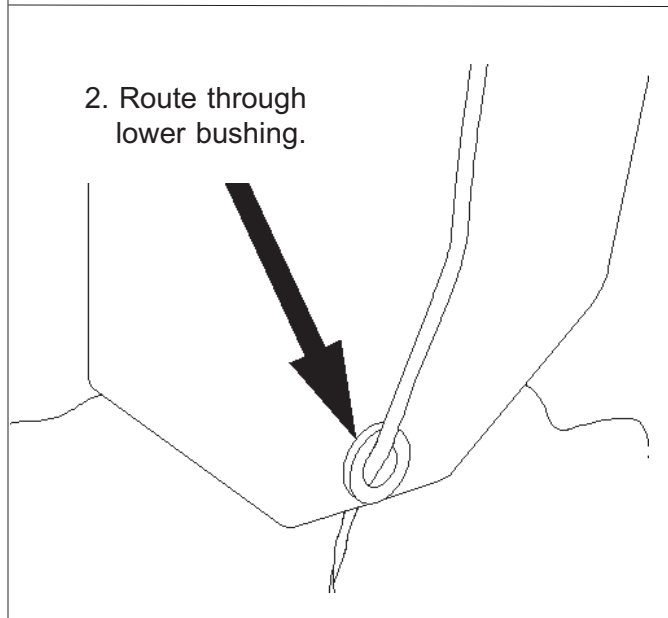
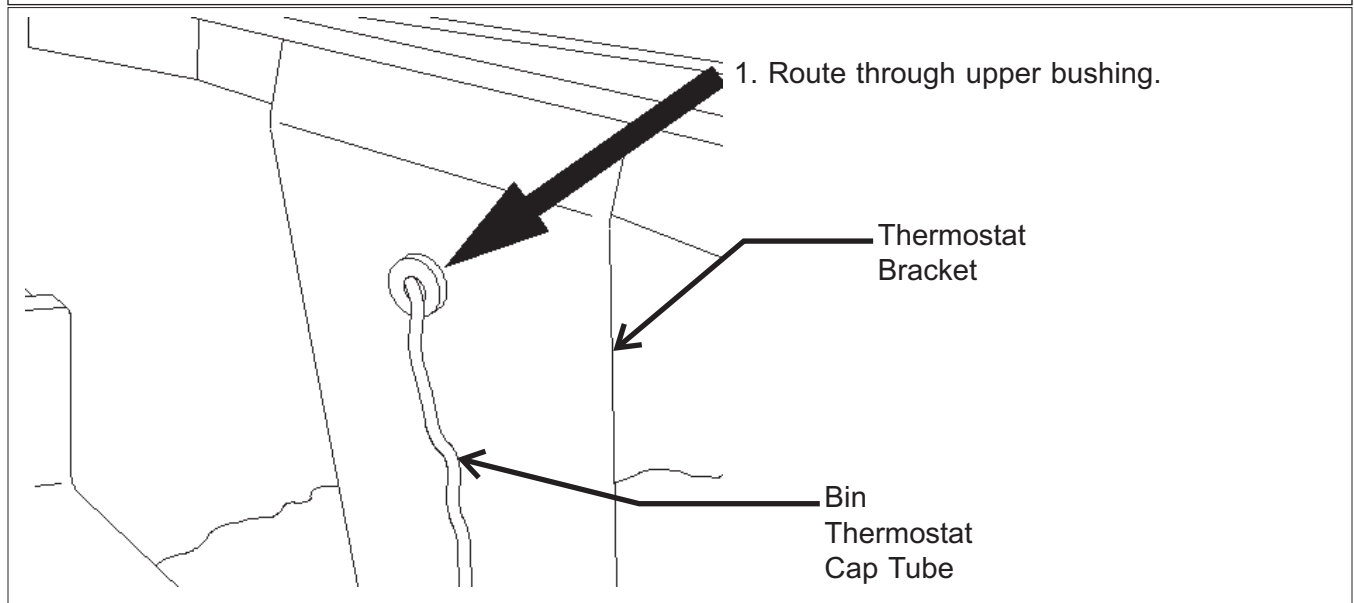
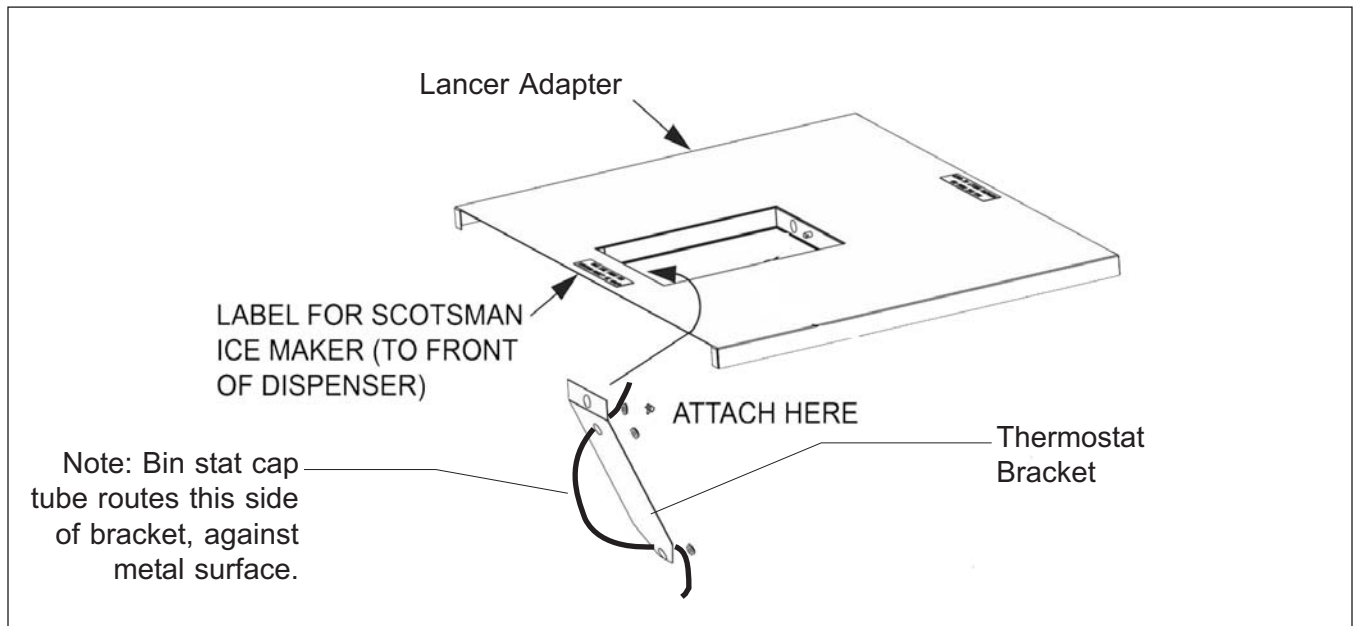

Dispensing Service Diagnosis of Nugget Ice Machine and Ice and Beverage Dispenser

Problem or Symptom	Possible Cause	Probable Fix
No ice is dispensed	No ice in dispenser	Check for power to ice machine
		Check thermostat
		Check control system, if shut down determine cause
		Check water supply
		Check refrigeration system
	Ice in dispenser, does not dispense	Check vend switch of dispenser
		Check dispenser door and solenoid, if used for no operation or sticking
		Check agitator drive motor
		Check agitator if turning, if not check for broken drive pin. Broken drive pin may be due to thermostat placement or incorrect cut in/out.
	Out of ice - too much demand.	
Ice in dispenser, but bridged over the dispense agitator. All the ice has been dispensed from under the bridge.	Check thermostat. Confirm it is in the correct spot, using the correct bracket, routed properly and is functioning.	
Ice dispenses but very slowly or erratically	Missing one or more kits or adjustments	Check for thermostat, bracket, adapter, cap tube routing, diverter use, agitation time errors.
	Damage to internal parts of dispenser	Check for bent agitator
	Ice sticking to dispense wheel	Check thermostat for cut in and cut out.
		Check refrigeration system for proper operation.
		Check agitation time settings - too frequent or too long will make ice fragment
	Customer overfilling cup, backs ice up into chute	Check position of restrictor plate
Excessive heat in room or near dispenser	Exhaust heat or move heat source away from dispenser	
Too much ice is dispensed	No restrictor plate	Add restrictor plate, set to 1.5" opening (Scotsman and Cornelius dispensers).

SERVICE BULLETIN

Subject: Panel change to the MDT2

The front and top panels for the MDT2 ice maker-dispenser have been changed. The change began with serial number 767396- 10T.

The seam between the front and top panels was a straight line, now it is curved so the cover of the bin can be removed without taking off the front panel.

This affects the service part numbers. The new numbers are:

- Top panel F660811-00
- Front panel F660812-01
- Front and top panel kit, includes both of the above F060600-03

The prior front and top panels will no longer be available, and are not interchangeable with the current panels. On a prior model that needs either the top or front panel, order the kit.

Curved Seam



New Panels

SERVICE BULLETIN

Subject: High Pressure Cut Out added to AFE400 air cooled.

A high pressure cut out switch has been added to the air cooled AFE400. The service part number is 11-0501-24. If the discharge pressure exceeds the cut out pressure setting, the switch will open and shut off the compressor. The switch will automatically reset when the pressure falls to the cut in pressure.

Cut Out is 260 PSIG, + -10 PSIG

Cut In is 160 PSIG, + -10 PSIG

Addition of this part began with serial number: 06021320011020

17-3094-01

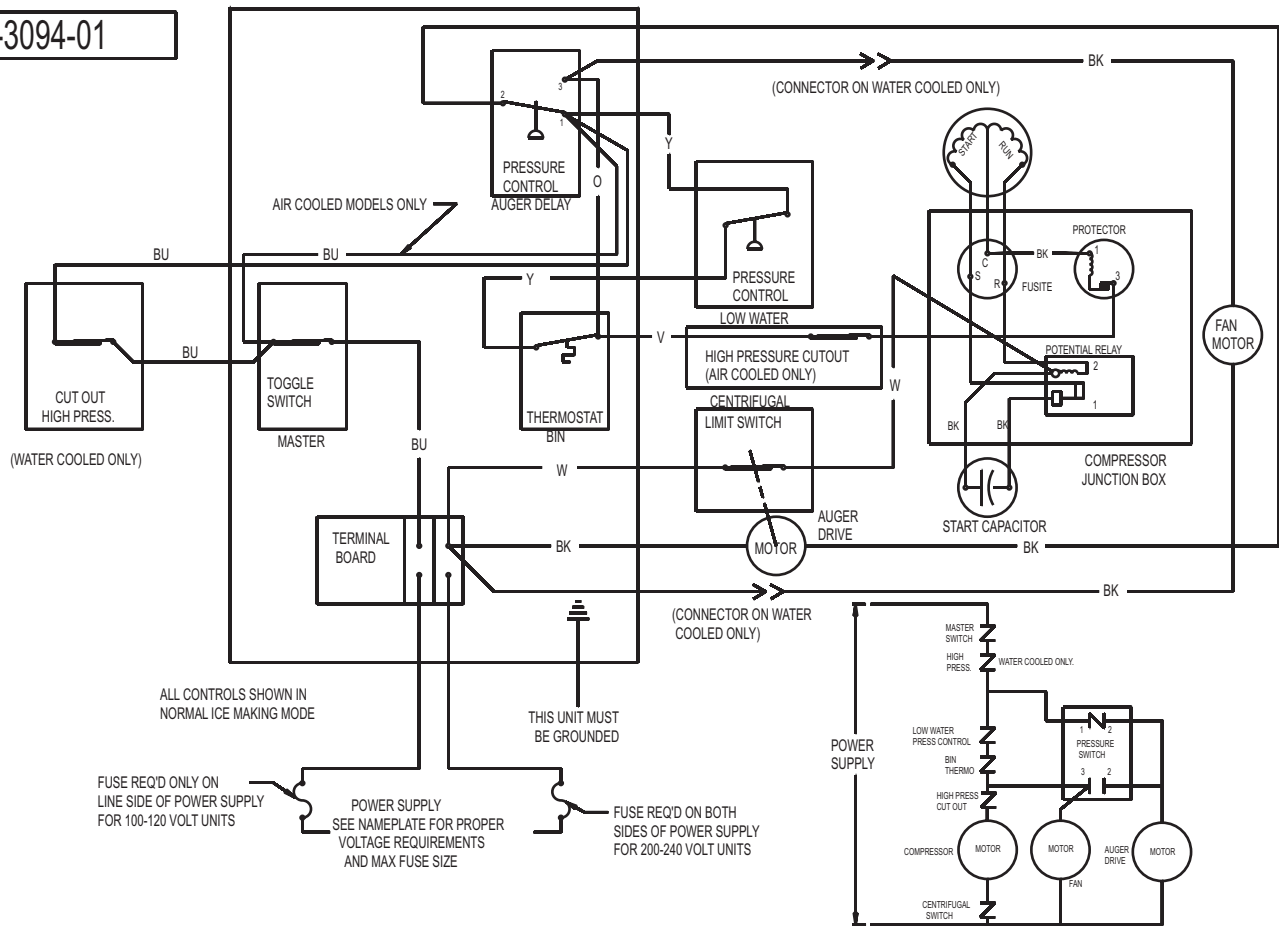

AFE400 Air Cooled Wiring Diagram, for those units with the high pressure cut out

SERVICE BULLETIN

Subject: Flake Gear Reducer Vent Change

The vent holes in the covers of all 1/10 HP gear reducers have been determined to be unnecessary and are being eliminated. This includes gear reducers in ice machines, complete gear reducers and individual service parts.

It is no longer necessary to remove the shipping vent plugs from any of these gear reducers.

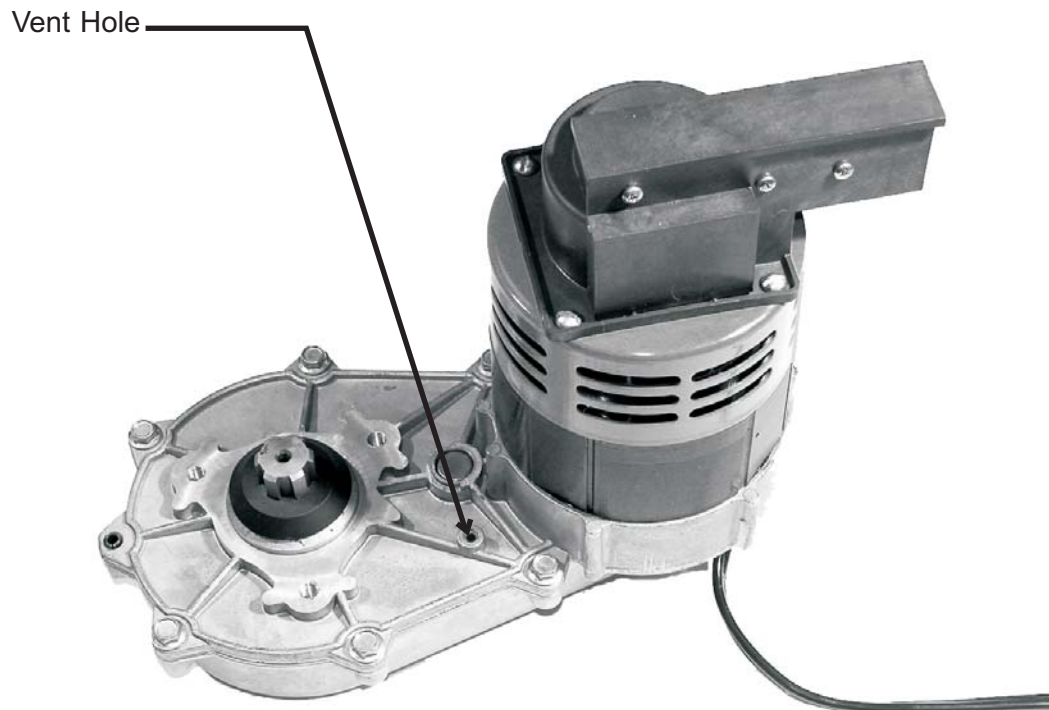



Bulletin Number: PS - 3 - 2006

Bulletin Date: March 2006

SERVICE BULLETIN

Subject: Panel and Air Flow Change on FME804, NME654, FME1204, NME954, FME1504RL and NME1254RL

The front panel on all the above models is changing from louvered to non-louvered. The air cooled models are also changing from non-louvered to louvered service panels. This changes their air-flow pattern from in the front and out the back to in the sides and out the back.

There will not be a model number or revision change; panel parts must be ordered as needed by part number for either louver or non louver applications. See the matrix below.

Note: Panel application is critical on air cooled models. The wrong panel will allow unfiltered air into the condenser, reduce air flow, or stop air flow completely.

New Part Number Matrix

	Front panel (not louvered)	Service Panel (louvered)	Air Filter Media
Air Cooled	A39048-001	A33946-002	A32975-001
Water Cooled	same	same	none
Remote	same	same	none
Remote Low Side (RL)	same	same	none

Prior Part Number Matrix

	Front panel (louvered)	Service Panel	Air Filter Media
Air Cooled	A33255-002	A34038-002 (not louvered)	02-2976-01
Water Cooled	same	A33946-002 (louvered)	none
Remote	same	A33946-002 (louvered)	none
Remote Low Side (RL)	same	A33946-002 (louvered)	none



Bulletin Number: PS - 4 - 2006

Bulletin Date: April 2006

SERVICE BULLETIN

Subject: HD30 Coin Mech Timer Change

The timer used by the HD30 coin vending model to time out the vend has been changed. It was a two part timer, but now is a single piece.

The change began with units produced 12/15/2005.

The prior timer parts are obsolete and no longer available. The new timer can be used in place of the old one by switching the position of the two wires on terminals 1 and 2. Refer to the tables below.

The new timer is part number **12-2948-21**

Wire Connections to Prior Timer	
Wire Color	Terminal Numbers
BK and R/W	1
BK	2
W/BU	3
O	6

Wire Connections to Current Timer	
Wire Color	Terminal Numbers
BK	1
BK and R/W	2
W/BU	3
O	6



Bulletin Number: PS - 5 - 2006

Bulletin Date: August 2006

SERVICE BULLETIN

Subject: Design change to BH1100, BH1300 and BH1600

The plastic top and plastic top filler panels have been changed. The hole in the top has been reduced (front to back) and the panels were changed to fit the new size hole. This does not affect placement of ice machines.

For current bins:

- 9 inch filler panel **02-4008-21** - 20.5" long
- 13.5 inch filler panel **02-4008-22** - 20.5" long
- Poly top with hole 45" wide x 20.5 deep 02-4008-17 (48") 02-4008-18 (60")
- SS frame 02-4008-16

For prior bins:

- 9 inch filler panel: 02-4008-19 - 21.5" long
- 13.5 inch filler panel: 02-4008-20 - 21.5" long
- Poly top with hole 45" wide by 21.5" deep. No longer available.
- SS frame. No longer available.

Another change is to the legs, the new legs are the standard Scotsman type, with 5/8 - 11 threads, kit KLP2E can be used as replacements on these bins..

These changes began with bins having a **January 2006 date code, 07F**.

Part number update:

- The left and right spring loaded hinges have been combined into one kit: **02-4008-23**
- The left and right door hinges have been combined into one kit: **02-4008-24**
- The upper and lower door tracks have been combined into one kit: **02-4008-25**



Bulletin Number: PS - 6 - 2006

Bulletin Date: September 2006

SERVICE BULLETIN

Subject: Color and Model Series Change

The color of certain plastic cabinet components, labels, emblems and doors is being changed to match the new Prodigy cuber color.

The date this change was implemented in production was August 21, 2006.

All models with a color change are designated with a series code of H at the end of the model number. Any model with a series code other than H is either not part of the color change or remains the prior color.

As the new and old colors are compatible, matching color service parts will not be available. Service parts will continue to be provided in the current color until they run out, then the new color will be supplied. The part numbers of the **affected components** will change, their current part numbers ending in -01 will be changed to a -31, and current part numbers ending in -02, will now end in -32. The -31 or -32 parts could be in either color.

SERVICE BULLETIN

Subject: New Refrigeration Access Valves

Scotsman has begun phasing out of the current access valves to a new type. The new type looks like a Schrader valve but is actually quite different. It is much less restrictive than a Schrader valve, so recovery, evacuation and recharging time will be minimally affected.

It is compatible with standard hose fittings. No special tools are required, but a Schrader core removal tool cannot be used with it.

The valve core part number is16-1139-01

The valve body & seat, without core, is part number16-1137-01.

The valve cap is part number16-1140-01

The first series of machines to receive these valves are the FME and NME models. Other models will be switching to this valve throughout 2007.

The first unit to receive the new access valve was FME804AS-1B, serial number 06111320014812.

The valve core can only be replaced on a system empty of refrigerant.

Typical Steps to replace the core:

- A. Recover the charge.
- B. Unscrew the core assembly, part number 16-1139-01.
- C. Install a new core. The torque spec for the valve core is 8 FT-LBS.
- D. Evacuate
- E. Weigh in new charge.
- F. Put the cap on the valve, secure it finger tight.

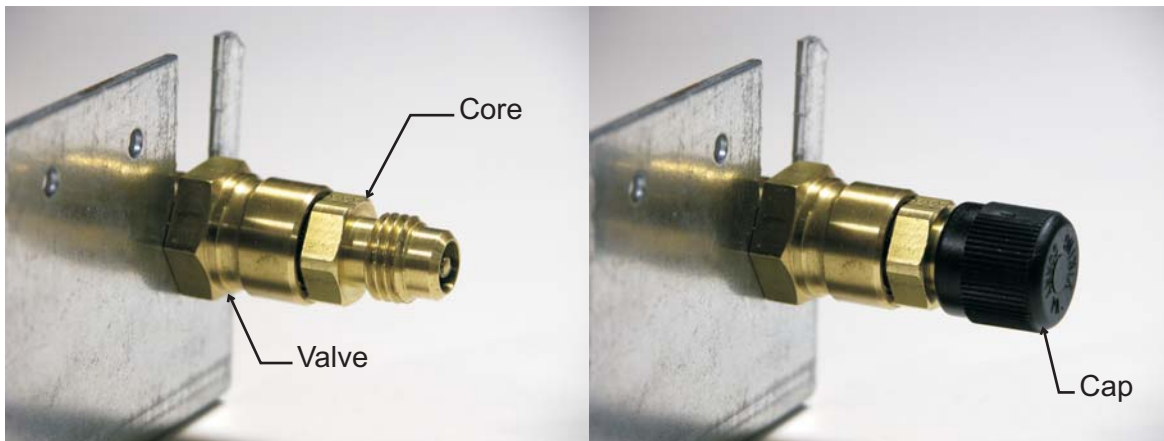

SERVICE BULLETIN

Subject: New 1/10 HP Gear Reducer

The gear reducer assembly used in the AFE325, AFE400, MDT3F12, MDT4F12 and MFE400 has been changed.

The **changes** include:

- New cover
- New case. The new case is sealed with a gasket instead of the prior o-ring.
- New output shaft bearing, output shaft and output gear.
- New gear reducer kit w/out motor.

Interchangeability:

- The new gear reducer can be used as a direct replacement for the prior 1/10 HP gear reducer.
- Most internal parts are NOT interchangeable with any prior 1/10 hp gear reducer. Only the 1st and 2nd gears and the motor were not changed and are interchangeable.

Availability:

- Prior internal parts will remain available.
- Covers and cases for the prior gear reducer will no longer be available.

Part Numbers:

- The gear reducer complete (115 volt) is part number: **02-4399-21**
- The gear reducer complete (230 volt, 50 Hz is part number: **02-4399-24**
- The gear reducer, with gears and oil, but w/out a motor is part number:**02-4398-21**

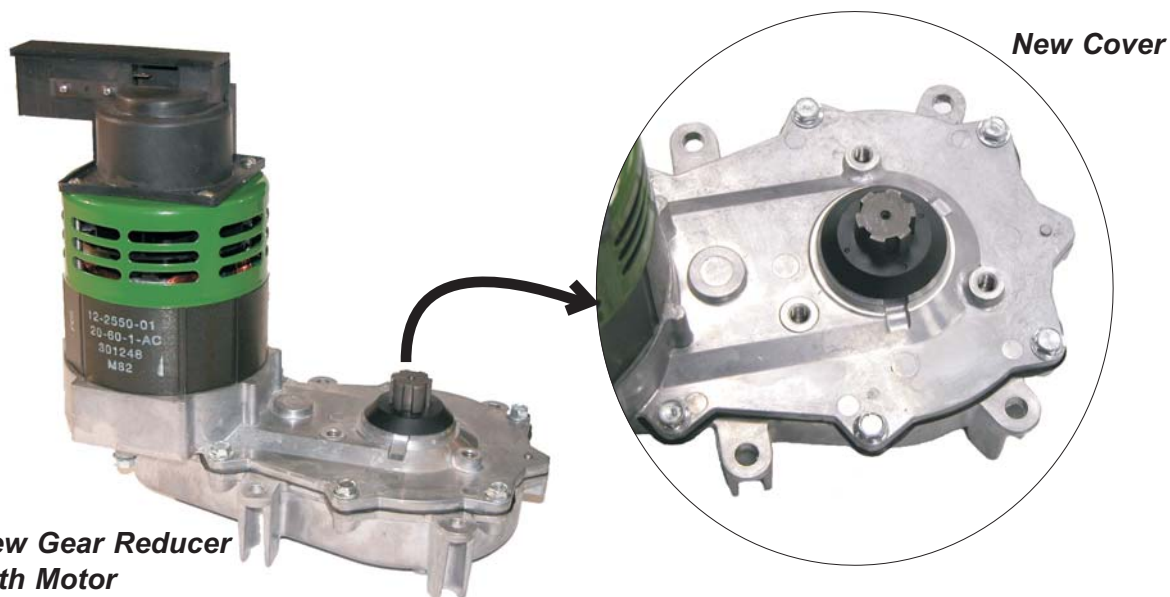

SERVICE BULLETIN

Subject: CSW45 Inlet Water Valve

The tubing connections for the CSW45 inlet water solenoid valve have changed from compression fittings to the push-in type fittings. This change occurred in mid-2006.

The new part number for the inlet water solenoid valve is W10139486. It replaces all prior CSW45 water valves. When replacing an inlet water valve with compression fittings, the inlet tubing must be replaced with tubing from the kit. To attach the outlet tubing (1/4" OD polyvinyl) remove the nut and metal insert, then push the tubing into the fitting on the valve.



SERVICE BULLETIN

Subject: 1/10 HP Breaker Bearing Design Change

Applies to MDT3, MDT4, AFE325, AFE400 and related prior models.

The breaker / bearing retainers for all of the 1/10 HP flakers have changed. The cap hook and cap have been replaced by a sealing cap that covers the entire top of the breaker or bearing retainer. The design change includes new part numbers for the replacement parts:

	Prior Number	New Number
AFE400 style	A26706-001	A09413-020
MDT3, MDT4 style	A14678-020	A14591-020
AFE325 style	A26707-001	A15508-020

The service kits are like the prior ones and are complete with a new bearing, and include instructions. Production of new units with the above change began in mid-April with MDT3F12A-1H, serial number 07041320014409.

Interchangeability:

The new parts can be used on prior models.

Replacement of a prior breaker in an MDT3 or MDT4 will require removal of some of the foam insulation at the top of the evaporator to allow space for the cap. Replacement of a prior breaker on an AFE400 eliminates use of the 13-0887-01 rubber cap and 13-0886-01 insulation halves.

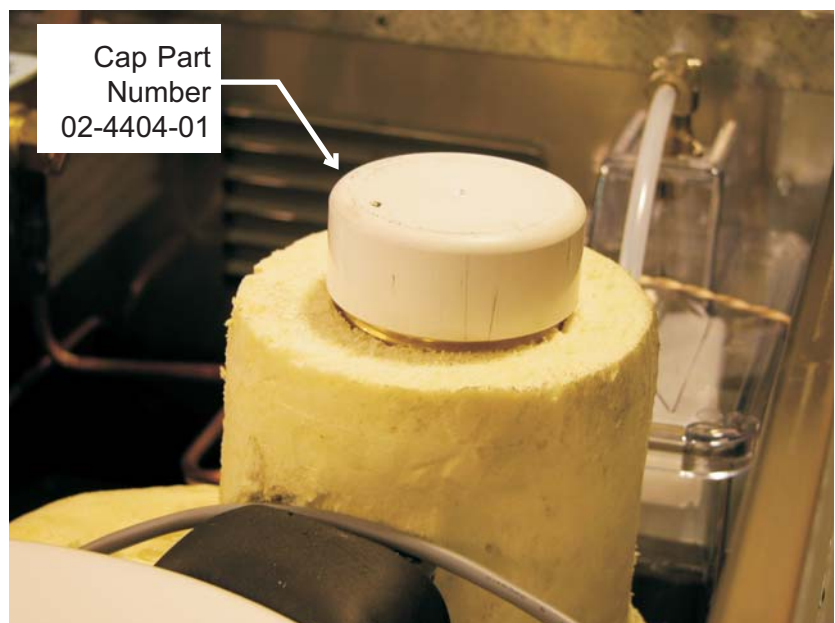

Service

The new threaded breaker requires a new method to pull an auger or remove the breaker. The steps below begin after the breaker to evaporator screws and in some cases the external spout have been removed.

There are two methods:

1. The flange on the outside of the breaker has indents in it so a screwdriver tip can be inserted between the flange and the top of the evaporator wall. Prying up on the flange should lift the auger and / or breaker out.

2. A low cost tool can be made using a 1 1/2" pipe thread tee.

A. Remove the sealing cap.

B. Install the Tee, it will screw onto the breaker, which has 1 1/2" NPT threads.

C. Pull up on the Tee or insert a bar thru the Tee and pull up on it.

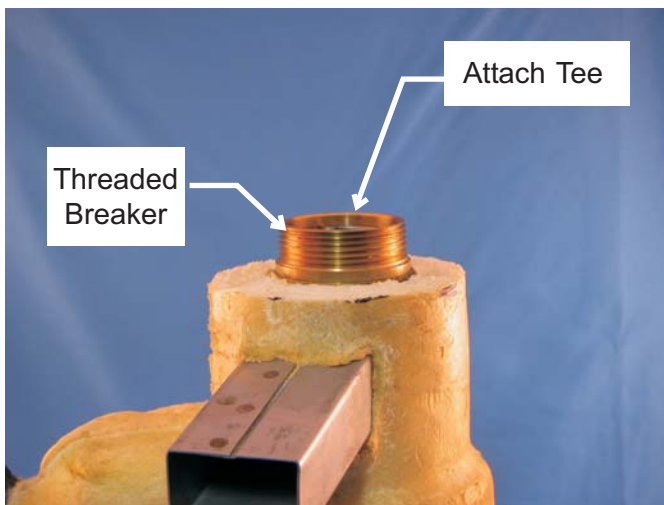

Method 2 - Sealing cap removed

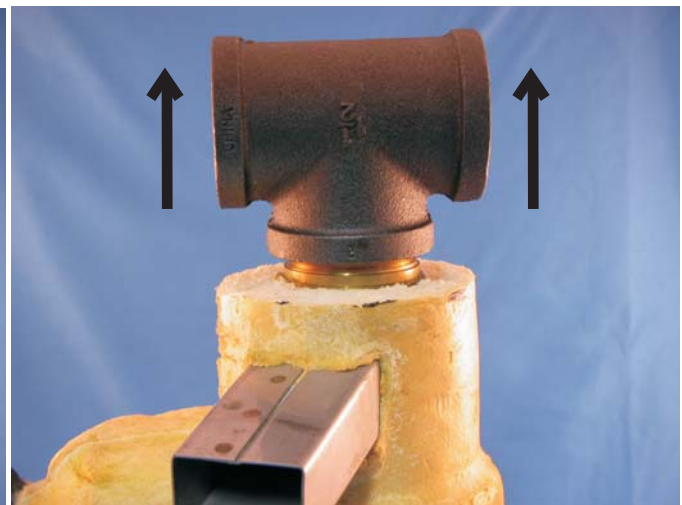

Method 2 - Tee Attached